



Your Reliable Source



Hawk has been designing and building high quality floor machines and specialty equipment in Elkhart, IN since 1995.

Hawk is an innovator in development of orbital floor machine technology. We currently offer five platforms of orbital equipment, making Hawk a leader in the industry.

Breakthrough technology continues with our exclusive "Floating Head" WD™ detachable handle machines. The results are substantial improvements in productivity and user safety. WD™ handles are now available on both rotary and orbital floor machines.

When it comes to custom design and private branding, look no further. No other machine manufacturer offers more choices, lower minimums or greater value than Hawk Enterprises.

Discover the Hawk Line

Floor Machines

Mighty Mini 10	4
Mighty 13, 15.....	5
Mighty 17,20	6
HD, XHD	7
HD 2-Speed, XHD 2-Speed	8
Brute, TEXHD Severe Duty	9
Brute 360	10
Pro Floor Restoration Machine.....	11

Floating Head Floor Machines

Glide Freedom, Glide XHD	12
Glide Freedom 2-Speed.....	13
Glide Sanding Star	14
Merlin TEXHD.....	15
Merlin 2-Speed XHD	16
Merlin 360	17

Orbital Floor Machines

G2 Raptor.....	18
RedTail 2014-180.....	19
TigerHawk 1410	20
TigerHawk 2014, 2814	21

High Speed Burnishers

High-Speed - DC Motor.....	22
High-Speed - AC Motor.....	23
Centerfold High Speed	24

Black Hawk Machines

BlackHawk FM Rotary Floor Machines.....	25
BlackHawk 1250 High Speed Burnisher.....	26
BlackHawk 1500 High Speed Burnisher.....	27

Air Movers

BVP25D Air Mover	28
BVP50 Air Mover.....	29
Industrial Air Mover	30
BPB25DA Axial Air Mover	31
BH25AD Axial Mover	32

Wet/Dry Tank Vacuums

V-20, 20 Gallon Tank Vacuum.....	33
V-29 & V-55, 29 & 55 Gallon Tank Vacuums.....	34
Harrier Backpack Vacuum.....	35

Specialty Equipment

Hot Shot Extractor	36
Osprey Chemical Sprayer.....	37
Flight Finish Applicator	38
Talon Edger Scrubber	39
Twin Talon Scrubber	40

Accessories

Claw Rotary Tool.....	41
Orbitec Rotary Tool	42
HAWK Scraper Tool	43
Rotary Floor Machine Accessories	44
Rotary Brushes & Pad Drivers.....	45
TigerHawk Orbital Floor Machine Accessories.....	46
Private Label Program	47





Hawk Mighty Mini 10
Countertops, Stairs,
Hard Surfaces
165 RPM
10"



Hawk Mighty
Small Area
Stripping, Scrubbing,
Polishing
165 RPM, 13", 15"



Hawk Mighty Global
Stripping, Scrubbing,
Polishing
165 RPM
17", 20"



Hawk HD
Stripping, Scrubbing,
Carpet Care
175 RPM,
13", 15", 17", 20"



Hawk XHD
Xtra Duty Stripping,
Scrubbing, Carpet Care
165 RPM,
13", 15", 17", 20"



Hawk 2-Speed
Stripping, Buffing,
Carpet Care
175/320 RPM,
13", 15", 17", 20"



Hawk XHD 2-Speed
Stripping, Buffing,
Carpet Care
165/300 RPM,
13", 15", 17", 20"



**Hawk Brute,
TEXHD, TE-CP**
Severe Duty Stripping,
Sanding, Resurfacing,
165 RPM
13", 15", 17", 20"



Hawk Brute 360,
Severe Duty with Dust
Pickup Stripping,
Sanding, Resurfacing
165 RPM
17", 20"



Hawk Pro
Professional Floor
Restoration Machine
165 RPM,
17", 20"



Hawk Glide Freedom
WD™ Floor Machines
Floor & Carpet Care
175 RPM - Glide
165 RPM - XHD
17", 20"



Hawk Glide Freedom
Dual-Speed
WD™ Floor Machines
175-320 RPM - Glide
165-300 RPM - XHD
17", 20"



Hawk Glide Sanding Star
WD™ Floor Machines
175 RPM - Glide
165 RPM - XHD
17", 20"



Hawk Merlin
Severe Duty Stripping,
Sanding, Resurfacing
WD™ Floor Machines
165 RPM
17", 20"



Hawk Merlin 360
Severe Duty with Dust
Pickup Stripping,
Sanding, Resurfacing
165 RPM
17", 20"



Hawk Merlin Dual-Speed
Severe Duty
WD™ Floor Machines
Strip, Scrub
165-300 RPM
17", 20"



Hawk G2 Raptor
Orbital Floor Machine
Scrub Wet/Dry Strip
1740 RPM
20" x 14"



Hawk RedTail 2014-180
Orbital Floor Machine
Surface Prep
1725 RPM
20" x 14"



Hawk 1410
Small Area Orbital
Floor Machine
1725 RPM
14" x 10"



Hawk 2014
Deluxe Orbital
1740 RPM - 20"x14"
Hawk 2814
Wide Area Orbital
1740 RPM - 28" x 14"



Hawk High Speed
Burnisher
DC 1500, 1800, 2000 RPM
AC 1000, 1250, 1500 RPM
13", 15", 17", 20"



Hawk High Speed
Centerfold Burnisher
Burnishing and
Refinishing
1500, 1800, 2000 RPM
13", 15", 17", 20"



BlackHawk FM
Rotary Floor Machine
Scrubbing, Stripping,
Polishing
175 RPM
17", 20"



BlackHawk
Burnishers
Burnishing and
Refinishing
1250 RPM, 20"
1500 RPM, 20"



Counter Tops, Stairs, Small Spaces

The performance, versatility and value of Hawk Mighty continues with the new Mighty Mini 10. The 1.0 HP TEFC (Totally Enclosed Fan cooled) AC motor drives a 10" rotary brush with risers, or a 9" pad driver with pads. Ample power in a small and manageable machine. Excellent balance with low center of gravity. Ideal for use in tight spaces, restrooms, edging and stairs.

Power

- 1.0 HP, 56C frame, dual capacitor, AC motor
- 115-230V, 50/60 Hz power
- The Hawk Mighty innovative design incorporates a state of the art "World Motor" acceptable for use throughout the globe
- 35 ft. 14-3 SJT 2-part power cord with molded plug for rigid handle models

Engineering

- Triple-planetary severe-duty 11:1 helical-cut industrial gears, case hardened with steel coupler
- Gears drive brushes and pads at 165 RPM
- All steel construction with welded, powder-coated frame
- 3 steel handle options - standard 48", short 24" and telescoping 36" to 48" with 6-position pin lock
- Comfortable vinyl dipped foam grips
- Thumb-operated safety switch
- Negative pressure on/off switch
- Dual steel operating triggers
- 1" x 5" non-marking ball bearing wheels

Safety Features

- Quiet 64 dB operation. Meets GS42 standard.
- Built with UL Listed components



Mighty Mini 10
w/ 48" Handle

Mighty Mini 10-24
w/ 24" Handle

Mighty Mini 10-TH
w/ Telescoping Handle



Specifications

Model	Mighty Mini 10	Mighty Mini 10-TH	Mighty Mini 10-24
Part #	F60-10	F60-10TH	F60-10-24
Pad Driver Size	9"	9"	9"
Brush with Riser	10"	10"	10"
Handle	Rigid / 48"	36" - 48" Telescoping	Rigid / 24"
Speed	165 RPM	165 RPM	165 RPM
Draw	5.9Amp	5.9 Amp	5.9 Amp
Weight	71 lbs.	70 lbs.	69 lbs.

All Models

Motor	1.0 HP, 56 frame, dual capacitor AC motor
Power Source	115-230V, 50/60 Hz power
Power Cord	2-Part, 35 ft. 14-3 power cord w/molded plug
Driver System	Triple-planetary XHD 11:1 helical-cut industrial gears
dB Rating	64 dB - Meets GS 42 Standard

Subject to Change Without Notice



Works in
Tight Spaces



Low Rise Profile - Easy
Working Under Sinks and
Partitions



Handle with 6-Position
Pin Lock



Telescoping Handle
Adjusts from 36" to 48"



Stripping, Scrubbing, Polishing



Mighty
w/ Telescoping
Handle

Mighty

Machine operators will appreciate the performance, versatility and value in the Hawk Mighty. The 1.0 HP TEFC AC motor and XHD gears deliver huge power in a small and manageable machine. The Mighty is ideal for use in tight spaces, restrooms, edging and stairs.

The TH model with telescoping handle fits every operator's height and store in tight spaces.

Power

- 1.0 HP, 56C frame, dual capacitor, AC motor
- 115-230V, 50/60 Hz power
- 50 ft. 14-3 SJT 2-piece power cord with molded plug for rigid handle models. Telescoping 13" and 15" use standard 5" cord

Drive System

- Triple-planetary severe-duty 11:1 helical-cut industrial gears, case hardened with steel coupler
- Gears drive brushes and pads at 165 RPM

Engineered Design

- All steel construction with welded, powder-coated frame
- Telescoping handle (TH models) adjusts from 36" to 48"
- 13" and 15" steel brush covers have full wraparound bumper
- One piece powder-coated, heavy duty steel handle with 6-position pin lock
- Comfortable vinyl dipped foam grips
- Thumb-operated safety switch. Negative pressure on/off switch.
- Dual steel operating triggers
- 1" x 5" non-marking ball bearing wheels

Safety Features

- Quiet 64 dB operation. Meets GS42 standard.
- Built with UL Listed components



Specifications

Model	MIGHTY13	MIGHTY 13-TH	MIGHTY15	MIGHTY15-TH
Part Number	F60-13	F60-13TH	F60-15	F60-15TH
Handle	Rigid	Telescoping	Rigid	Telescoping
Size	13"	13"	15"	15"
Pad Size	12"	12"	14"	14"
Telescoping Handle	No	Yes	No	Yes
Pad Speed	165 RPM	165 RPM	165 RPM	165 RPM
Amp Draw	4.9 Amp	4.9 Amp	6 Amp	6 Amp
Weight	87 lbs.	87 lbs.	88 lbs.	88 lbs.

All Models

Motor	1.0 HP, 56 frame, dual capacitor AC motor
Power Source	115-230V, 50/60 Hz power
Power Cord	50 ft. 14-3 SJT power cord w/molded plug
Driver System	Triple-planetary XHD 11:1 helical-cut industrial gears
dB Rating	64 dB - Meets GS42 standard



Works in
Tight Spaces



Telescoping Handle
Adjusts from 36" to 48"



Optional 2.5-Gallon
Solution Tank



Handle with 6-Position
Pin Lock

Subject to Change Without Notice



Stripping, Scrubbing, Polishing

Machine operators will appreciate the performance, versatility and value of the Hawk Mighty. The 1.0 HP TEFC AC motor and XHD gears deliver huge power in a small and manageable machine. The 48" machine is built with a 4-position pin-lock design. Use the 17" and 20" Mighty for the big jobs.



Mighty 17"

Mighty 20"

Power

- 1.0 HP, 56C frame, dual capacitor, AC motor
- 115-230V, 50/60 Hz power
- 50 ft. 2-piece 14-3 power cord with molded plug

Drive System

- Triple-planetary severe-duty 11:1 helical-cut industrial gears, case hardened with steel coupler
- Gears drive brushes and pads at 165 RPM

Engineered Design

- All steel construction with welded, powder-coated frame
- 17" and 20" steel brush cover with wraparound bumper
- One piece powder-coated, heavy duty steel handle with 4-position pin lock. Comfortable vinyl-dipped foam handle grips.
- Thumb-operated safety switch
- Negative pressure on/off switch
- Dual steel operating triggers
- 1" x 5" non-marking ball bearing wheels

Safety Features

- Quiet 64 dB operation. Meets GS42 standard.
- Built with UL Listed components



Specifications

Model	Mighty 17	Mighty 20
Part #	F60-17	F60-20
Size	17"	20"
Pad Size	16"	19"
Speed	165 RPM	165 RPM
Amp Draw	7 Amp	8 Amp
Weight	90 lbs.	93 lbs.

All Models

Motor	1.0 HP, 56 frame, dual capacitor AC motor
Power Source	115-230V, 50/60 Hz power
Power Cord	50 ft. 14-3 SJT power cord w/molded plug
Driver System	Triple-planetary XHD 11:1 helical-cut industrial gears
dB Rating	64 dB - Meets GS42 standard

Subject to Change Without Notice



Handle with 4-Position Pin Lock

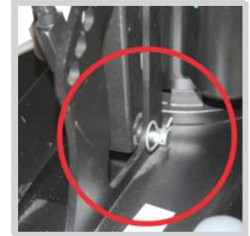

Remove the Handle Mounting Pin w/o Tools



Optional 2.5-Gallon Solution Tank

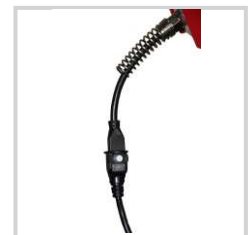

Two Piece 14-3 Pig-Tail Power Cord



Stripping, Scrubbing, Carpet Care

The Hawk HD provides maximum power with the twin capacitor AC motor and Hawk's ruggedly reliable floor machine size. Both HD and XHD are powered by the 1.5 HP motor and offered with a wide range of tools, accessories and optional weights.

The optional DX package adds the 4 gallon solution tank, custom fit splash guard and premium pad driver.

Power

- 1.5 HP, 66 frame, dual capacitor AC motor. Chromed motor cover.
- 115V, 60 Hz power, (230V optional)
- 50 ft. 14-3 SJT (HD) or 12-3 SJTOW (XHD) power cord
- **HD** uses triple-planetary HD 10:1 helical-cut commercial gears drive brushes and pads at 175 RPM.
- **XHD** (Extra Heavy Duty) planetary 11:1 helical-cut industrial gears, case hardened with steel coupler. drive brushes and pads at 165 RPM.

Engineered Design

- All steel construction with welded, powder-coated frame
- One piece, chromed heavy-duty steel handle with variable position lock and vinyl-dipped foam grips
- Powder-coated steel brush covers with full wraparound bumpers
- Dual steel operating triggers. Negative pressure on/off switch.
- Thumb-operated safety switch. 1" x 5" non-marking wheels.
- Optional frame weights (XHD only)

Safety Features

- Quiet 60dB (HD) and 66 dB (XHD) operation. Meets GS42 Standard.
- UL / CUL listed



HAWK HD

HAWK XHD



Welded Steel Frame, Handle and Brush Cover



XHD Machines Have 11:1 Ratio



DX Model Includes Pad Driver, Solution Tank & Splash Guard



Brush Covers in 7 Stock Colors Plus Chrome

Specifications HD

Specifications XHD

Model Part #	HP1513-HD F13-01	HP1515-HD F15-03	HP1517-HD F17-01	HP1520-HD F20-01	HP1513-XHD F23-01	HP1515-XHD F25-03	HP1517-XHD F27-01	HP1520-XHD F30-01
Machine Size	13 inch	15 inch	17 inch	20 inch	13 inch	15 inch	17 inch	20 inch
Pad Size	12 inch	14 inch	16 inch	19 inch	12 inch	14 inch	16 inch	19 inch
Pad Speed	175 RPM	175 RPM	175 RPM	175 RPM	165 RPM	165 RPM	165 RPM	165 RPM
Amp Draw	5.5 Amp	5.7 Amp	5.9 Amp	6.5 Amp	5.3 Amp	5.6 Amp	6.1 Amp	6.8 Amp
Weight	87 lbs.	91 lbs.	94 lbs.	97 lbs.	87 lbs.	90 lbs.	94 lbs.	99 lbs.
	ALL HD SIZES				ALL XHD SIZES			
Motor	1.5 HP, 66 frame, dual capacitor AC				1.5 HP, 66 frame, dual capacitor AC chrome cover motor			
Drive System	Triple-planetary 10:1 helical-cut commercial gears				Triple-planetary XHD 11:1 helical-cut industrial gears			
Power Source	115-230V, 60 Hz (50 Hz optional)				115-230V, 60 Hz (50 Hz optional)			
Power Cord	50 ft. 14-3 SJT industrial w/molded plug				50 ft. 14-3 SJTOW industrial w/molded plug			
dB Rating	60 dB - Meets GS42 standard				66 dB - Meets GS42 standard			

Subject to Change Without Notice



Stripping, Scrubbing, Carpet Care

The Hawk 2-Speed floor machine is rough and versatile. Change between low and high speed as the job requires. Powered by a 1.5 HP DC rectified motor.

Choose the HD for standard scrubbing and stripping at 175/320 RPM. The XHD model uses 11:1 helical cut gear set for more challenging work including carpet care and natural stone maintenance. Both models have a toggle speed switch at the top of the handle. XHD models can be weighted for greater performance.

Power

- 1.5 HP, 66 frame, DC rectified 2-speed motor. 115V, 60 Hz power.
- 50 ft. 14-3 STO industrial cord w/molded plug
- **HD** uses triple-planetary HD 10:1 helical-cut commercial gears. Drives brushes and pads at 175/320 RPM.
- **XHD** (Extra Heavy Duty) planetary 11:1 helical-cut industrial gears, case hardened with steel coupler. 165/300 RPM pad speed.

Engineered Design

- All steel construction with welded, powder-coated frame
- One piece, chromed heavy duty steel handle with variable position lock and vinyl-dipped foam grips
- Powder-coated steel brush covers with full wraparound bumpers
- Dual steel operating triggers. Negative pressure on/off switch.
- Thumb-operated safety switch. 1" x 5" non-marking wheels.
- Optional frame weights (XHD only)

Safety Features

- Quiet 60dB (HD 2-Speed) and 66 dB (XHD 2-Speed) operation. Meets GS 42 Standard. UL / CUL listed.



Hi/Lo Speed Motor Switch on Handle



Easy Transport with 1" x 5" Non-Marking Ball-Bearing Wheels



Brush Covers in 7 Stock Colors Plus Chrome



DX Model Includes Pad Driver, Solution Tank & Splash Guard



Specifications HD 2-Speed

Specifications XHD 2-Speed

Model	HP1513-2S	HP1515-2S	HP1517-2S	HP1520-2S	HP1513-2S-XHD	HP1515-2S-XHD	HP1517-2S-XHD	HP1520-2S-XHD
Part #	F03-13-01	F03-15-01	F03-17-01	F03-20-01	F04-13-01	F04-15-01	F04-17-01	F04-20-01
Machine Size	13 inch	15 inch	17 inch	20 inch	13 inch	15 inch	17 inch	20 inch
Pad Size	12 inch	14 inch	16 inch	19 inch	12 inch	14 inch	16 inch	19 inch
Pad Speed	175/320 RPM	175/320 RPM	175/320 RPM	175/320 RPM	165/300 RPM	165/300 RPM	165/300 RPM	165/300 RPM
Amp Draw	7.8/8.2 Amp	8.1/8.5 Amp	8.5/9.1 Amp	9.2/9.5 Amp	7.8/8.2 Amp	8.1/8.5 Amp	8.5/9.1 Amp	9.2/9.5 Amp
Weight	87 lbs	91 lbs	94 lbs	97 lbs	87 lbs	90 lbs	94 lbs	99 lbs

ALL HD 2-Speed Sizes

ALL XHD 2-Speed Sizes

Motor	1.5 HP, 66 frame, DC rectified 2-speed motor	1.5 HP, 66 frame, DC rectified 2-speed motor
Drive System	Triple-planetary 10:1 helical-cut commercial	Triple-planetary XHD 11:1 helical-cut industrial gears
Power Source	115-230V, 60 Hz (50 Hz optional)	115-230V, 60 Hz (50 Hz optional)
Power Cord	50 ft. 14-3 STO industrial w/molded plug	50 ft. 14-3 STO industrial w/molded plug
dB Rating	60dB (175) - 69dB (320) - Meets GS42 standard	69dB(165) - 72dB (300) - Meets GS42 standard

Subject to Change Without Notice



Stripping, Sanding, Carpet Care, Resurfacing



Brute

The Brute is built for high productivity in the harshest jobs like concrete resurfacing, natural stone polishing, and wood screening and sanding. We fit the powerful 1.5 HP 180 frame TEFC (Totally Enclosed Fan Cooled) AC motor with 11:1 gears and industrial grade steel coupler. You will power your Brute without blowing breakers and reducing down time.

The 100% steel construction is accented with three exterior decorations:

- **Brute** - chrome motor and brush cover
- **TE-CP** - chrome motor with powder coated brush cover
- **TE** - powder-coated motor cover (black) and brush cover

Power

- 1.5 HP, 180 frame, TEFC dual capacitor AC motor
- 115-230V, 60 Hz (50 Hz optional)
- 50 ft. 12-3 SJTOW industrial power cord with molded plug

Drive System

- Triple-planetary XHD 11:1 helical-cut industrial gears, case hardened with steel coupler, driving brushes at 165 RPM

Engineered Design

- All steel welded construction. Steel brush covers with full wrap around bumper.
- One piece chrome, heavy duty steel handle w/variable position lock
- Dual steel operating triggers with negative pressure on/off switch. Thumb-operated safety switch. Comfortable vinyl-dipped foam grips.
- 1" x 5" non-marking ball bearing wheels
- Optional 4 gallon solution tank. Optional frame weights.

Safety Features

- Quiet 66 dB operation. Meets GS42 standard.
- UL/CUL listed



Specifications				
Machine Size	13"	15"	17"	20"
Model	-	HP1515-180 Brute	HP1517-180 Brute	HP1520-180 Brute
Part #	-	F35-CP	F37-CP	F40-CP
Motor / Brush Cover	-	Chrome/Chrome	Chrome/Chrome	Chrome/Chrome
Model	HP1513-180 TE	HP1515-180 TE	HP1517-180 TE	HP1520-180 TE
Part #	F33-01-B	F35-01-B	F37-01-B	F40-01-B
Motor Cover	Black	Black	Black	Black
Brush Cover	Powder-Coated	Powder-Coated	Powder-Coated	Powder-Coated
Model	HP1513-180 TECP	HP1515-180 TECP	HP1517-180 TECP	HP1520-180 TECP
Part #	F33-01-C	-	F37-01-C	F40-01-C
Motor Cover	Chrome	-	Chrome	Chrome
Brush Cover	Powder-Coated	-	Powder-Coated	Powder-Coated
Pad Speed	165 RPM	165 RPM	165 RPM	165 RPM
Amp Draw	7.2 Amp	7.5 Amp	7.9 Amp	8.4 Amp
Weight	113 lbs.	117 lbs.	123 lbs.	125 lbs
All Sizes				
Motor	1.5 HP, 180 frame, TEFC dual capacitor AC motor			
Power	115-230V, 60 Hz power			
Power Cord	50 ft. 12-3 SJTOW industrial power cord w/molded plug			
Drive System	Triple-planetary XHD 11:1 helical-cut industrial gears			
dB Rating	66 dB - Meets GS42 standard			



Optional Dust Pickup System with Vacuum Connection



Add the 25 lb. Custom "U" Weights for Fast Results



7 Private Brand Colors Plus Chrome



Power for Optional Drivers & Tools

Subject to Change Without Notice



Shown with an Optional Weight Set

Stripping, Sanding, Resurfacing & Polishing

The Brute 360 is built for high productivity in the harshest jobs like concrete resurfacing, natural stone polishing, and wood screening and sanding. Designed with the powerful 1.5 HP 180 frame TEFC (Totally Enclosed Fan Cooled) AC motor, fit with 1:11 hardened helical cut gears and an industrial grade steel coupler. This combination of motor and gears weighs 30 pounds more than a standard machine of similar size.

The machine is built with the HAWK 360™ dust pickup system, using a 16 gauge steel, powder-coated brush cover with a 360 degree dust collecting duct and 2" dust exhaust port. All commercial tank vacuums with a 1.5" or 2" hose connect to this port. Remove the heaviest soils by adding the optional 50 lb. weight set with transport lock.

Power

- 180 frame TEFC dual capacitor AC motor
- 115-230V, 60 Hz power. (50 Hz optional).
- 50 ft., 2-pc. 12-3 SJTOW industrial yellow power cord with twist-lock plug
- Extra heavy duty XHD steel helical-cut 11:1 gears with steel coupler

Engineered Design

- Proprietary HAWK 360™ brush cover with wrap-around dust guard picks up dusts and debris
- Extra heavy duty steel handle with vacuum hose support
- Heavy duty motor guard protects the motor from impact damage
- Dual steel operating triggers with negative pressure on/off switch
- Thumb-operated safety switch. Comfortable vinyl-dipped foam grips.
- 2" x 6" non-marking load bearing, ball bearing wheels
- Optional (2) 25 lb. removable weight set, with locking pins and transport lock (#A360-17-2 -17"), (#A360-20-2 - 20").

Safety Features:

- Quiet 66 dB operation. Meets GS42 standard.
- UL/CUL listed



Specifications

Model	HP1517BRUTE-BDC (Black)	HP1520BRUTE-BDC (Black)
Part #	F38-B (Black)	F41-B (Black)
Model	HP1517BRUTE-CDC (Chrome)	HP1517BRUTE-CDC (Chrome)
Part Number	F38-C (Chrome)	F41-C (Chrome)
Machine Size	17 inch	20 inch
Pad Size	16 inch	19 inch
Pad Speed	165 RPM	165 RPM
Amp Draw	7.9 Amp	8.4 Amp
Machine Wt.	133 lbs.	135 lbs.

All Sizes

Motor	1.5 HP, 180 frame, TEFC dual capacitor AC motor
Power	115-230V, 60 Hz power (50 Hz optional)
Power Cord	50 ft. 2-piece 12-3 SJTOW yellow industrial power cord w/twist-lock plug
Drive System	Triple-planetary XHD 11:1 helical-cut industrial gears
dB Rating	66 dB - Meets GS42 standard

Subject to Change Without Notice



The Handle-Mounted Hose Support Carries 1.5" and 2" Vacuum Hoses



Variable Handle Height Adjustment and Transport Lock



The Steel Brush Cover is Built with a 1.5" or 2" Vacuum Port



360° Duct in the Brush Apron Directs Debris to the 2" Vacuum Port



Stripping, Scrubbing, Resurfacing



The Hawk Pro is designed for the floor care professional. This severe duty machine handles the range of tasks with the 180-frame TEFC motor with hardened steel gears that drive scrapers, sanders and tools at 165 RPM.

The Pro includes two removable 25 lb. weights mounted on the brush cover, a convenient upper handle lock, 3" wider handle, a no-spill solution tank, pad driver and splash guard.

Power

- 1.5 HP, 180 frame, TEFC dual capacitor AC motor
- 115-230V, 60 Hz power
- 50 ft., 2-pc. (12-3) SJTOW industrial power cord with twist-lock plug

Drive System

- Triple-planetary XHD 11:1 helical-cut industrial gears, case hardened with steel coupler. Gears drive brushes and tools at 165 RPM.

Engineered Design

- All steel construction with welded, powder-coated frame
- Heavy duty motor guard protects the motor from impact damage
- One piece chrome, heavy duty steel handle with variable position lock
- Ergonomic upper grip handle is 3" wider than standard for leverage. Comfortable vinyl-dipped foam grips.
- 17" and 20" steel brush covers with full wraparound bumpers
- Dual steel operating triggers. Thumb operated safety switch.
- Negative pressure on/off switch
- 1" x 5" non-marking ball bearing wheels
- Includes premium pad driver
- Includes 4 gallon solution tank and splash guard
- Includes removable 50 lb. weight set with mounting lock pins. Added weights give extra down pressure for faster results.

Safety Features

- Quiet 66 dB operation. Meets GS42 standard.
- UL/CUL listed



Specifications

Model	HP1517-180PRO	HP1520-180PRO
Part #	F37-03 PRO	F040-03-A
Machine Size	17 inch	20 inch
Pad Size	16 inch	19 inch
Pad Speed	165 RPM	165 RPM
Amp Draw	7.9 Amp	8.4 Amp
Weight	128 lbs.	130 lbs.

All Sizes

Motor	1.5 HP, 180 frame, TEFC dual capacitor AC motor
Power	115-230V, 60 Hz power (50 Hz optional)
Power Cord	50 ft. (12-3) SJTOW industrial power cord w/twist-lock plug
Drive System	Triple-planetary XHD 11:1 helical-cut industrial gears
dB Rating	66 dB - Meets GS42 standard

Subject to Change Without Notice

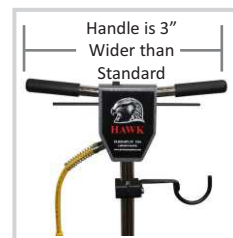

The Handle-Mounted Hose Support Carries 1.5" and 2" Vacuum Hoses



Includes Solution Tank, Pad Driver & Splash Guard



Two-Part Twist Lock Power Cord



Upper Handle Lock is Easy to Access



Stripping, Scrubbing, Carpet Maintenance

The Hawk Glide delivers up to twice the performance of traditional floor machines, with greater safety and 1/3 less amp draw. The unique "Floating Head" Wheels Down handle carriage design provides 100% contact with the floor and steers the Glide in forward and backward movement - unlike the side-to-side movements of swing-buffers. Use the XHD model for the toughest jobs with 11:1 industrial gears to power tools and drivers at 165 rpm. Easy to learn. Easy to use.

Power

- 1.5 HP, 66 frame, dual capacitor AC motor
- 115V, 60 Hz power, (230V optional)
- 50 ft. 2-piece 12-3 SJT yellow industrial cord w/ twist-lock plug (Freedom) or 12-3 SJTOW (XHD) power cord twist-lock plug
- **Glide Freedom** uses triple-planetary HD 10:1 helical-cut commercial gears to drives brushes and pads at 175 RPM
- **Glide XHD** (Extra Heavy Duty) uses triple-planetary XHD 11:1 helical-cut industrial gears, case hardened with steel coupler. Drives brushes and pads at 165 RPM.

Engineered Design

- Exclusive WD™ Wheels Down detachable handle carriage design produces 100% flat contact with the floor
- All steel construction with welded frame. Heavy duty powder-coated steel handle with 4-position pin lock.
- 17" and 20" steel brush covers with full wraparound bumper
- Dual steel operating triggers. Thumb-operated safety switch.
- Comfortable vinyl-dipped foam handle grips
- 2" x 6" non-marking ball bearing wheels
- **Glide Deluxe** model (#F91-17-DX, #F91-20-DX) starts with the chrome motor Glide XHD and adds 4 Gallon solution tank, premium pad driver and splash guard
- Optional 4 gallon solution tank - black and natural colors
- Optional splash guard and dust collection kit

Safety Features

- Quiet 66 dB operation. Meets GS42 standard.
- Built with UL approved components



Glide Freedom

Glide XHD



Specifications

Model	Glide 17	Glide 17XHD	Glide 20	Glide XHD
Part #	F91-17-01	F92-17-01	F91-20-01	F92-20-01
Machine Size	17"	17"	20"	20"
Brush Size	15"	15"	18"	18"
Motor Cover	Powder Coat	Chrome	Powder Coat	Chrome
Gear Box	10:1	11:1	10:1	11:1
Pad Speed	175 RPM	165 RPM	175 RPM	165 RPM
Amp Draw	6.7 Amp	7.1 Amp	6.9 Amp	7.3 Amp
Weight	113 lbs.	113 lbs.	115 lbs.	115 lbs.
dB Rating	66 dB	69 dB	66 dB	69 dB

All Models

Motor	1.5 HP, 66 frame dual capacitor AC motor
Power Source	115V, 60Hz power. (230V Optional)
Power Cord	50 ft. 2-piece 14-3 JT (Glide) or 12-3 SJTOW (Glide XHD) Yellow industrial power cord w/twist-lock plug



Optional 4 Gallon Solution Tank



Optional Dust Control Ring Connects to Tank Vacuum



50 ft. Twist-Lock Power Cord

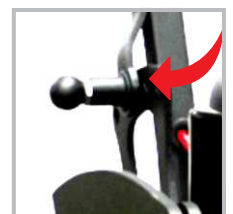

4 Position Pin Lock Handle All Steel Construction

Subject to Change Without Notice



Stripping, Scrubbing, Carpet Maintenance



The Hawk Glide 2-Speed machine delivers up to twice the performance of traditional floor machines. The unique "Floating Head" handle carriage design provides 100% contact with the floor and steers the Glide in forward and backward movement - unlike the side-to-side movements of swing-buffers. The 2-speed motor scrubs at 165 RPM (Glide) or 175 RPM (XHD). Polish at 300 RPM (Glide) or 320 RPM (XHD).

Power

- 1.5 HP, 66 frame, dual capacitor AC motor
- 115V, 60 Hz power, (230V optional)
- 50 ft. 2-piece 14-3 SJT (**Glide 2-Speed**) or 12-3 SJTOW (**Glide 2-Speed XHD**) power cord with molded plug
- Hi/Low speed switch is mounted on the motor
- **Glide 2-Speed** uses triple-planetary HD 10:1 helical-cut commercial gears to drives brushes at 175 and 320 RPM.
- **Glide 2-Speed XHD** (Extra Heavy Duty) uses triple-planetary XHD 11:1 helical-cut industrial gears which are case hardened with steel coupler. Drives brushes and pads at 165 or 300 RPM.

Engineered Design

- 17" and 20" steel brush cover with full wraparound bumper
- Exclusive WD™ Wheels Down detachable handle carriage design produces 100% flat contact with the floor
- All steel construction with welded frame. Heavy duty powder-coated steel handle with 4-position pin lock.
- Dual steel operating triggers. Thumb-operated safety switch.
- Comfortable vinyl-dipped foam handle grips
- 2" x 6" non-marking ball bearing wheels
- Optional 4 gallon solution tank - black and natural colors
- Optional splash guard and dust collection kit

Safety Features

- Quiet 66 dB operation. Meets GS42 standard.
- Built with UL approved components



Specifications

Model	GLIDE 17-2S	GLIDE 17-2SXHD	GLIDE 20-2S	GLIDE 20-2SXHD
Part #	F0091-17-2S	F0091-17-2SXHD	F0091-20-2S	F0091-20-2SXHD
Gear Box	10:1	11:1	10:1	11:1
Machine Size	17"	17"	20"	20"
Pad Size	16"	16"	19"	19"
Pad Speed	175/320 RPM	165/300 RPM	175/320 RPM	165/300 RPM
Amp Draw	8.5/9.1 Amp	8.5/9.1 Amp	9.2/9.6 Amp	9.2/9.6 Amp
Power Cord	50', 14-3 SJT	50' 12-3 SJTOW	50' 14-3 SJT	50', 12-3 SJTOW
Weight	113 lbs.	113 lbs.	115 lbs.	115 lbs.
All Models				
Motor - Glide	66 frame, 1.5 HP rectified 2-speed DC motor			
Power	115V, 60 Hz. (230V optional)			
dB Rating	62 dB (low speed) - 69 dB (high speed) Meets GS42 Std.			



Optional 4 Gallon Solution Tank



Optional Dust Control Ring Connects to Tank Vacuum



2-Speed Motor Switch on Motor

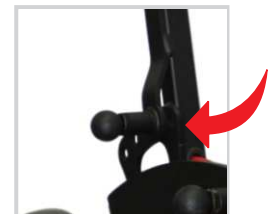

4-Position Pin Lock Handle All Steel Construction

Subject to Change Without Notice



Glide Sanding with Active Dust Control



The Glide Sanding Star makes wood floor maintenance faster and easier. Designed to be nimble for scuffing, blending and sanding on all types of finished wood, bare wood, VCT and coated floors.

We combine the Glide “floating-head” Wheels Down frame design with the Hawk Mighty 1.0 HP DC motor, and mount our six quart, triple-filter vacuum on the powder-coated steel handle carriage. The Sanding Star uses XHD 11:1 industrial gears to spin floor sanding drivers at 165 RPM. A twist-lock plug securely connects the machine to its 100 ft. (12-3) industrial power cord.

The HAWK 360 Dust Pickup System™ collects airborne dust and debris internally at the floor level with its proprietary 360 degree duct system. Floor preparation debris control is made safe and simple.

Power

- Powerful 1.0 HP TEFC dual capacitor motor
- 115-230V 50/60 Hz AC power
- 100 ft. 2-pc. (12-3) SJTOW power cord with twist-lock connection
- XHD 11:1 helical-cut case hardened gears with steel coupler spins sanding drivers at 165 RPM

Engineered Design

- Exclusive WD™ detachable handle-carriage design with 5-position pin-set handle lock
- HAWK 360 Dust Pickup System™ makes sanding cleaner
- Includes handle-mounted, 6 quart dual-stage tank vacuum with triple filtration
- 2" x 8" non-marking ball bearing wheels
- Welded, powder-coated handle with vinyl-dipped foam grips
- Dual steel operating triggers with negative pressure on/off switch
- Includes 20 lb. weight and 360 degree dust ring

Safety Features

- Quiet 66 dB operation. Meets GS42 standard.



Specifications

Model	Sanding Star 17"	Sanding Star 17" w/ Vacuum	Sanding Star 20"	Sanding Star 20" w/ Vacuum
Part #	F95-17-01	F95-17-01S	F95-20-01	F95-20-01S
Machine Size	17"	17"	20"	20"
Pad Size	16"	19"	16"	19"
Pad Speed	165 RPM	165 RPM	165 RPM	165 RPM
Gear Box	11:1	11:1	11:1	11:1
Amp Draw	6.7 Amp	6.7 Amp	7.1 Amp	7.1 Amp
Weight	137 lbs.	147 lbs.	139 lbs.	149 lbs.

All Models

Motor	1.0 HP, 56 frame dual capacitor powder-coated AC motor
Power	115V/230V, 50-60 Hz power
Power Cord	100 ft. 2-piece (12-3) SJTOW w/ twist-lock connection
dB Rating	66 dB Meets GS42 standard

Subject to Change Without Notice



360 Degree Duct in Brush Apron Directs Debris to Vacuum Port



Includes Handle Mounted 6 Quart Tank Vacuum

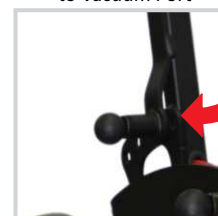

5 Position Pin Lock Handle



Two-Piece Twist Lock 100 ft. Power Cord



Stripping, Scrubbing, Resurfacing

Merlin floor machines are built for high productivity in harsh environments like concrete resurfacing and natural stone polishing. The unique WD™ Wheels Down “Floating Head” design provides 100% pad contact with the floor and perfect operator control. Easier operation and faster production times are what sets this unit apart from standard rotary designs. Do heavy work with less energy. Breaks down into multiple pieces for moving by a single person.

The 100% steel construction is accented with three exterior decorations:

- **Merlin** - All industrial powder coat
- **Merlin CP** - Chrome motor with powder coat brush cover
- **Merlin DX** - Adds pad driver, splash guard and chrome motor

Power

- 1.5 HP, 180 frame, TEFC Dual Capacitor AC motor with 11:1 industrial gears
- 115-230V, 60 Hz power
- 50 ft. 2-pc. 12-3 SJTOW yellow twist lock plug
- Triple-planetary XHD 11:1 helical-cut industrial gears, case hardened with steel coupler drives brushes and tools at 165 RPM.

Engineered Design

- Handle disassembles in 60 seconds for easy transport and storage
- All steel construction with welded “Floating Head” frame
- Heavy duty powder-coated steel handle with 5-position pin lock
- The heavy duty motor guard protects the motor from impact damage
- Thumb-operated safety switch. Dual steel operating triggers.
- Negative pressure on/off switch
- 2” x 8” non-marking load bearing wheels
- Includes 80 lb. weight set
- Optional 28 lb. carriage weight kit
- Increase productivity with the optional solution tanks

Safety Features

- Quiet 66 dB operation. Meets GS42 standard.
- UL/CUL listed



Specifications

Model	HP1517-180-MER	HP1520-180-MER
Part #	F70-01	F70-20-01
Motor / Cover	Black Powder Coated Motor & Brush Cover	Black Powder Coated Motor & Brush Cover
Model	HP1517-180-MER-CP	HP1520-180-MER-CP
Part Number	F70-01-C	F70-20-01-C
Motor / Cover	Chrome Motor & Black Powder Coated Frame	Chrome Motor & Black Powder Coated Frame
Machine Size	17 inch	20 inch
Pad Speed	165 RPM	165 RPM
Amp Draw	7.9 Amp	8.5 Amp

All Sizes

Motor	1.5 HP, 180 frame, TEFC dual capacitor AC motor
Power	115-230V, 60Hz power. 50 Hz optional.
Power Cord	50 ft. 2-pc. (12-3) SJTOW w/ yellow twist lock plug
Drive System	Triple-planetary XHD 11:1 helical-cut industrial gears
dB Rating	66 dB - Meets GS42 standard



Two Piece Twist Lock Connects Machine to 50 ft. Power Cord



8" Wheels for Transport

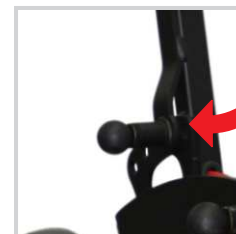

5-Position Pin Lock Handle All Steel Construction



Optional Carriage Weight Kit (28. lbs.)



Stripping, Scrubbing, Restoration



Includes 80#
Weight Kits

The Merlin 2-Speed takes advantage of innovative engineering to set new records in production and user safety. The unique “Floating Head” handle carriage design provides 100% contact with the floor, and steers the Merlin in forward and backward movement - unlike the side-to-side movements of traditional swing-buffers. The Merlin 2-Speed draws 1/3 less amps than standard machines. Strip and scrub floors at 165 RPM. Buff and polish at 300 RPM.

Power

- 1.5 HP, 66 frame, DC rectified 2-speed motor
- Hi-Lo 2-speed toggle switch mounted on motor
- 115V, 50/60 Hz power, (230V optional)
- 50 ft. 12-3 SJTOW, 2-piece yellow power cord with twist lock plug

Drive System

- Triple-planetary XHD 11:1 helical-cut industrial gears, case hardened with steel coupler drives brushes and pads
- 165 and 300 RPM

Engineered Design

- WD™ “Wheels Down” 5-position pin-lock handle disassembles in 60 seconds for transport and storage
- All steel construction with welded powder coated frame
- 17” and 20” steel brush cover with wraparound bumper
- Thumb-operated safety switch. Negative pressure on/off switch.
- Dual steel operating triggers.
- 2” x 8” non-marking load bearing, ball bearing wheels
- Includes removable 80# weight set

Safety Features

- Quiet operation – 66 dB (low speed), 72dB (high speed). Meets GS42 standard.
- UL / CUL Listed



Specifications

	HP1517-MER-2SXHD	HP1520-MER-2SXHD
Model #	HP1517-MER-2SXHD	HP1520-MER-2SXHD
Part #	F0040-17-1.5TE-2S	F0040-20-1.5TE-2S
Machine Size	17 inch	20 inch
Pad Size	16 inch	19 inch
Pad Speed	165 / 300 RPM	165 / 300 RPM
Amp Draw (Low/High Speed)	8.5 / 9.1 Amp	9.2 / 9.6 Amp
All Sizes		
Motor	1.5 HP, 66 frame, DC rectified 2-speed motor	
Power	115V, 50/60 Hz power, (230V optional)	
Drive System	Triple-planetary XHD 11:1 helical cut industrial gears	
Power Cord	50 ft. 12-3 SJTOW, 2-piece yellow power cord with twist lock plug	
dB Rating	66 dB (low speed) - 72 dB (high speed) operation Meets GS42 standard	

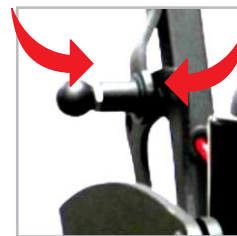

5-Position Pin Lock Handle All Steel Construction



Two-Part Twist Lock Connects Machine to 50 ft. Power Cord



2-Speed Motor with Hi/Lo Switch



80 lb. Weights Available. Mounts on Apron with Locking Pins

Subject to Change Without Notice



Stripping, Sanding, Resurfacing & Polishing



Includes
80# Weight Kit

The Hawk Merlin 360 combines the “Floating Head” engineering design with the proprietary HAWK 360™ dust pick up system. The system collects airborne dusts and debris in the brush cover. A 2” top-mounted dust port connects to all commercial tank vacuums with 1.5” or 2” hose. Cutting, polishing and floor sanding debris control is safe and simple.

The Merlin 360 is built for high productivity in harsh environments like concrete resurfacing and natural stone polishing. It is powered by a 180 frame TEFC Dual Capacitor AC motor with severe-duty, helical-cut 11:1 gear drive.

Power

- 180 frame TEFC dual capacitor AC motor
- 115-230V, 60 Hz power. (50 Hz optional).
- 50 ft., 2-pc. 12-3 SJTOW industrial power cord with Twist Lok plug
- Extra heavy-duty steel helical-cut 11:1 gear drive with steel coupler

Engineering Design

- Proprietary 360™ dust pick up brush cover with wrap around dust guard Wd™. Wheels-Down, Xtra Heavy-Duty steel handle with 5 position pin-set lock
- Motor power to drive scrapers, diamond tools and sanding tools
- Foot operated Lift Assist lever for easier transport
- The heavy duty motor guard protects the motor from impact damage
- Dual steel operating triggers with negative pressure on/off switch
- Thumb-operated safety switch with comfort cushion grips
- 2” x 8” non-marking load bearing, ball bearing wheels
- Includes removable weight set with (4) 20 lb. weights and locking pins
- Optional (2) 25 lb. carriage kit.

Safety Features:

- Built in dust collection
- Quiet 66 dB meets GS42 standard.
- UL/CUL listed



Specifications

	HP1517MER-BDC (Black)	HP1520MER-BDC (Black)
Model	HP1517MER-BDC (Black)	HP1520MER-BDC (Black)
Part #	F75-17B	F75-20B
Model	HP1517MER-CDC (Chrome)	HP1520MER-CDC
Part Number	F75-17B	F75-20C
Machine Size	17 inch	20 inch
Pad Size	16 inch	19 inch
Pad Speed	165 RPM	165 RPM
Amp Draw	7.9 Amp	8.5 Amp
Weight	233 lbs.	235 lbs.

All Sizes	
Motor	1.5 HP, 180 frame, TEFC dual capacitor AC motor
Power	115-230V, 60Hz power. 50 Hz optional.
Power Cord	50 ft. 2-pc. (12-3) SJTOW w/ yellow twist lock plug
Drive System	Triple-planetary XHD 11:1 helical-cut industrial gears
dB Rating	66 dB - Meets GS42 standard

Subject to Change Without Notice



Carriage Weight Set fits Merlin TEXHD, Merlin 360



5 Handle Heights with Pin-Set Lock



Brush Shroud is Built with 2” Vacuum Port



360 Degree Duct in Brush Apron Directs Debris to Vacuum Port



Dry Stripping, Scrubbing, Stripping

The Hawk G2 Raptor has a 20 inch wide rectangular head and is easy to maneuver with less vibration and operator fatigue than other orbiting brands. The G2 Raptor easily reaches into corners and along baseboards.

The G2 Raptor strips floor finish without chemicals. It is excellent for sanding, scrubbing and stone polishing. Easy to learn. Easy to use.

Power

- 1.5 HP, 180 frame, TEFC dual capacitor AC motor
- 115-230V, 60 Hz power
- 50 ft. 2-pc., 12-3 SJTOW industrial yellow power cord. Twist-lock plug connects machine to power cord.
- Eccentric balanced design drives pads at 1740 RPM

Engineered Design

- Four 2" vibration isolators
- Heavy-duty powder-coated steel handle with adjustable handle lock
- Thumb-operated safety switch
- Dual steel operating triggers
- Comfortable vinyl-dipped foam handle grip
- 2" x 8" non-marking ball bearing wheels
- Optional active Vacuum System includes 6 quart tank vacuum, dust skirt and hardware (#TH1001-RAP).

Safety Features

- Quiet 60 dB operation. Meets GS42 standard.
- UL/CUL listed



Specifications

Model	HAWK G2 Raptor
Part Number	F98-RAP
Pad Size	20" x 14"
Pad Speed	1740 RPM
Power Source	115-230V, 60 Hz power
Motor	1.5 HP, 180 frame, TEFC dual capacitor AC motor
Amp Draw	9 Amp
Power Cord	50 ft. 2-pc. 12-3 SJTOW yellow power cord with twist-lock plug
Weight	194 lbs. (0.657 lbs/in ²)
Drive System	Eccentric balanced orbital drive
Vibration Isolators	(4) Industrial 2" vibration isolators
dB Rating	66 dB - Meets GS42 standard



Milled Dust Control Access



Optional Dust Control Kit #TH1001-RAP



8" Wheels for Easy Transport



Industrial 2" Vibration Isolators

Subject to Change Without Notice



Surface Preparation, Scrubbing, Refinishing



The HAWK RedTail 2014-180 is great for surface preparation and cleaning of hard surfaces - sanding, stripping, and stone polishing. The unique WD™ Wheels Down “Floating Head” design provides 100% pad contact with the floor and perfect operator control. The handle is easily removed for transport and storage.

The 180 frame HD motor, severe-duty helical-cut gears and 1740 RPM orbital pad speed, makes the RedTail ideal for the harshest jobs.

Power

- 1.5 HP, 180 frame, TEFC dual capacitor AC motor
- 115-230V, 60 Hz
- 50 ft. 14-3 STW power cord with molded plug

Drive System

- Eccentric balanced orbital drive works at 1740 RPM

Engineering Design

- The exclusive orbital technology reduces vibration and makes scrubbing easier, with less operator fatigue
- WD™ Wheels Down “Floating Head” welded steel frame
- Heavy duty, powder-coated steel handle with 5-position pin lock
- Comfortable operation with vinyl-dipped foam handle grips
- Thumb operated safety switch
- Dual steel operating triggers
- Negative pressure on/off switch
- 2” x 6” non-marking ball bearing wheels
- Optional dust control kit (#TH1011-RT)
- Optional 4 gallon solution tank

Safety Features

- Quiet 66 dB operation. Meets GS42 standard.
- Built with UL approved components



Specifications

Model	REDTAIL-2014-180
Part #	F98-RT180
Pad Size	20” x 14”
Pad Speed	1740 RPM
Motor	1.5 HP, 180 frame, TEFC Dual Capacitor AC
Power Source	115-230V, 60 Hz power
Amp Draw	7.1 Amp
Power Cord	50 ft., 14-3 SJTOW power cord with molded plug
Weight	171 lbs.
Pad Pressure	0.61 lbs/in ²
Drive System	Eccentric balanced orbital drive
Vibration Isolator	(4) primary, (6) secondary
dB Rating	66dB - Meets GS42 standard

Subject to Change Without Notice

Subject to Change Without Notice



Orbiting Pads and WD™ Handle - Works in Tight Spaces



Disassembles Without Tools for Easy Transport & Storage



Unique Vibration Damping Design



Optional Dust Control Kit #TH1011-RT



Dry Stripping, Scrubbing, Stripping

The TigerHawk 1410 revolutionary rectangular "Floating Head" machine is easy to maneuver, with less vibration and less operator fatigue than other orbiting brands. The Wheels-Down WD™ handle design assures 100% pad contact with the floor. The 1410 works three times faster than rotary floor machines, easily reaching into corners and along baseboards. Add the optional 2.5 gallon solution tank for even greater productivity.

The TigerHawk 1410 can strip large areas of floor finish without chemicals. The 1410 is excellent for sanding, scrubbing and stone polishing. Easy to learn. Easy to use.

Power

- 0.5 HP, 56C frame, TEFC single capacitor AC motor
- 115-230V, 60 Hz AC power
- 50 ft. 14-3 SJT power cord with molded plug

Drive System

- Eccentric balanced orbital design drives pads at 1725 RPM

Engineered Design

- Dual vibration isolation system
- Heavy duty powder-coated steel handle with 5-position pin lock
- Built with vacuum port. Order vacuum equipment separately.
- Thumb-operated safety switch. Dual steel operating triggers.
- Negative pressure on/off switch
- 1" x 5" non-marking ball bearing wheels
- Optional dust skirt and vacuum assembly kit (#TH1011-1410)
- Increase wet productivity with optional Osprey Sprayer Kit (#TH1010-MTY) and 2.5 gal. solution tank (#0001-BLK2.5)

Safety Features

- Quiet 66 dB operation. Meets GS42 standard.
- Built with UL listed components



Specifications

Model	TH-1410
Part #	F98-TH-1410
Pad Size	14" x 10"
Pad Speed	1725 RPM
Motor	0.5 HP, 56C frame, TEFC single capacitor AC motor
Power Source	115-230V, 60 Hz
Power Cord	50 ft., 14-3 SJT power cord w/molded plug
Amp Draw	8.3 Amp
Drive System	Eccentric balanced orbital drive
Vibration Isolators	(4) 1.25" isolaters
Weight	107 lbs., 0.57 lbs./sq.in.
Down Pressure	0.57 lbs./sq. in.
dB Rating	66 dB - Meets GS42 standard

Subject to Change Without Notice Notice



Floating Head Frame with 1.5" Vacuum Port



Optional Full Wraparound Dust Skirt #TH1011-1410



(4) Rubber Vibration Isolators



Welded Powder-Coated Steel Handle and Frame Construction



Dry Stripping, Scrubbing, Stripping

The TigerHawk 2014 and 2814 with revolutionary WD™ wheels down “Floating Head” technology are the most productive orbitals on the market. With over 0.79 pounds per square inch of pressure moving at over 1740 RPM, you power through finish removal without the use of chemicals. Scrub, strip, or sand floors effortlessly with less noise and fatigue.

Our large 180 frame 1.5 HP TEFC motor is connected to a solid steel drive plate and balanced via easy access eccentric driver. 12 vibration isolators combined with Hawk exclusive handle-carriage mounting system prevents any vibration to be felt by the operator. The handle removes easily for transport and storage. Includes 4 caster steel transport dolly and drip tray.

Power

- 1.5 HP, 180 frame, TEFC dual capacitor AC motor
- 115-230V, 60 Hz power
- 50 ft. 2-pc. 12-3 SJTOW yellow industrial power cord with twist-lock plug
- Eccentric balanced design drives pads at 1740 RPM

Engineered Design

- Dual vibration isolation system
- Heavy-duty powder-coated steel handle with 5-position pin lock
- The WD™ handle is easy to remove for transport and storage
- The heavy duty motor guard protects the motor from impact damage
- Thumb-operated safety switch. Dual steel operating triggers.
- Comfortable vinyl-dipped foam handle grip
- 2" x 8" non-marking ball bearing wheels
- Optional active Vacuum System includes 6 quart tank vacuum, dust skirt and hardware (#TH1001).
- Optional Osprey Sprayer System includes motor-mounted sprayer pump, 4 gallon solution tank and hardware (#TH1010).
- Includes transport cart and drip tray

Safety Features

- Quiet 60 dB operation. Meets GS42 standard.
- UL/CUL listed



TigerHawk 2014

TigerHawk 2814



Specifications

Model Number	TH-2014	TH-2814
Part Number	F98-TH2014	F98-TH2814
Pad Size	20" x 14"	28" x 14"
Pad Speed	1740 RPM	1740 RPM
Amp Draw	7.1 Amp	7.8 Amp
Weight	250 lbs.	305 lbs.
Pad Pressure	0.89 lbs/in ²	0.79 lbs/in ²

All Models

Motor	1.5 HP, 180 frame, TEFC dual capacitor AC motor
Power Source	115-230V, 60 Hz power
Power Cord	50 ft. 2-pc. 12-3 SJTOW yellow industrial power cord w/twist-lock plug
Drive System	Eccentric balanced orbital drive
Vibration Isolators	(6) primary, (8) secondary isolaters
dB Rating	60 dB - Meets GS42 standard



Steel Frame with Rear Vacuum Port



Works Along Baseboards and Into Corners



Two-Part Twist Lock Connects Machine to 50 ft. Power Cord



Includes Transport Cart and Drip Tray

Subject to Change Without Notice



Burnishing & Refinishing



The Hawk High Speed is known for its balance, durability and value. HawkK offers the largest selection of burnishers in four sizes; 13", 15, 17" and 20" and three speeds; 1500, 1800 and 2000 RPM.

The 17" and 20" Active Dust Control DC models include a dust ring and filter, the perfect addition to any Green Cleaning program.

Power

- 1.5 HP, 66 frame, DC rectified motor. 115V, 50/60 Hz power. 230V optional.
- 50 ft. 14-3 STO industrial power cord with molded plug
- Multi V-Belt drives pads at 1500, 1800 and 2000 RPM

Engineering Design

- Welded steel frame. One piece chromed heavy duty steel handle with variable position positive lock.
- 13", 15", 17" and 20" steel brush covers with full wraparound bumper
- 17" and 20" Dust Control models include a dust ring and filter
- Thumb operated safety switch
- Negative pressure on/off switch
- Dual steel operating triggers
- Comfortable vinyl-dipped foam grip handle.
- 1" x 5" non-marking ball-bearing wheels
- Includes flexible pad holder with pad centering clamp

Safety Features

- Quiet operation - 69 dB (Standard), 62 dB (Dust Control). Meets GS42 standard.
- UL/CUL listed (1500 rpm model)
- Built with UL listed components



Specifications

Machine Pad Size	13" Standard 13"	15" Standard 15"	17" Standard 17"	17" Dust Control 16"	20" Standard 20"	20" Dust Control 19"
Speed	1500 RPM					
Model #	HP1513-HSB	HP1515-HSB	HP1517-HSB	HP1517-1500HSBDC	HP1520-HSB	HP1520-1500HSBDC
Part #	F1500-13	F1500-15	F1500-17	F1500-17DC	F1500-20	F1500-20DC
Amp Draw	9.1 Amp	9.6 Amp	13.0 Amp	12.2 Amp	13.8 Amp	13.1 Amp
Speed	1800 RPM					
Model #	HP1513-1800	HP1515-1800	HP1517-1800	HP1517-1800DC	HP1520-1800	HP1520-1800DC
Part #	F1800-13	F1800-15	F1800-17	F1800-17DC	F1800-20	F1800-20DC
Amp Draw	9.5 Amp	9.9 Amp	13.9 Amp	13.2 Amp	14.6 Amp	13.6 Amp
Speed	2000 RPM					
Model #	HP1513-2000	HP1515-2000	HP1517-2000	HP1517-2000DC	HP1520-2000	HP1520-2000DC
Part #	F2000-13	F2000-15	F2000-17	F2000-17DC	F2000-20	F2000-20DC
Amp Draw	10.0 Amp	10.8 Amp	14.9 Amp	13.9 Amp	16.4 Amp	14.8 Amp

All Models

Motor	1.5 HP, 66 frame DC rectified motor					
Power	115V, 50/60 Hz power. 50 ft. 14-3 STO industrial power cord with molded plug. (230V Optional)					
Belt Drive	Multi-V belt drive					
dB Rating	69 dB	69 dB	69 dB	62 dB	69 dB	62 dB
Machine Weight (all)	84 lbs.	86 lbs.	88 lbs.	90 lbs.	90 lbs.	92 lbs.

Subject to Change Without Notice



Burnishing & Refinishing

The Hawk High-Speed Burnisher with AC motor is a balanced force of polishing power. The models are built with a durable 1.5 HP TEFC (Totally Enclosed Fan Cooled) motor that requires little maintenance. The enclosure protects the inner working of the motor from dust and moisture, running cleaner than traditional motors. The AC motor runs at lower amp draw than most DC motors. Hawk AC burnishers are the perfect addition to any Green Cleaning program.

Power

- 1.5 HP, 56C frame, TEFC dual capacitor AC motor
- 115-230V, 60 Hz power
- 50 ft., 14-3 STO industrial power cord with molded plug

Drive System

- Multi V-Belt drives pads at 1000 RPM

Engineering Design

- 13", 15", 17" and 20" standard models are built with powder coated steel brush cover with full wraparound bumper
- 17" and 20" Dust Control models add a dust ring and filter
- Welded steel frame.
- One-piece chrome handle with variable position positive handle lock
- Comfortable vinyl-dipped foam handle grips
- Thumb-operated safety switch.
- Negative pressure on/off switch
- Dual steel operating triggers
- 1" x 5" non-marking wheels
- Includes flexible pad holder with pad centering clamp

Safety Features

- Quiet operation - 58 dB (Standard), 53 dB (Dust Control). Meets GS42 standard.
- Built with UL listed components



High Speed Burnisher
with AC Motor
and Dust Control

High Speed Burnisher
with AC Motor



Specifications

Machine	13" Standard	15" Standard	17" Standard	17" Dust Control	20" Standard	20" Dust Control
Pad Size	13"	15"	17"	16"	20"	19"
Model #	HP1513-1000	HP1515-1000	HP1517-1000	HP1517-1000DC	HP1520-1000	HP1520-1000DC
Part #	F1000-13TE	F1000-15TE	F1000-17TE	F1000-20TEDC	F1000-17TE	F1000-20TEDC
Speed	1000 RPM	1000 RPM	1000 RPM	1000 RPM	1000 RPM	1000 RPM
Amp Draw	10.0 Amp	11.2 Amp	12.4 Amp	11.6 Amp	13.5 Amp	12.4 Amp
Motor	1.5 HP, 56C frame, TEFC dual capacitor AC motor					
Power	115-230V, 60 Hz power. 50 ft. 14-3 STO industrial power cord with molded plug					
Drive	Multi-V belt drive					
dB Rating	58 dB	58 dB	58 dB	53 dB	58 dB	53dB
Machine Weight	84 lbs.	86 lbs.	88 lbs.	88 lbs.	90 lbs.	90 lbs.

Subject to Change Without Notice



Burnishing & Refinishing



The Hawk Centerfold High-Speed Burnisher with DC motor is renowned for its balance, durability and value. The non-locking handle allows the buffing pad to keep constant pad pressure, assuring a consistent floor shine and steady amp draw. The fold-up handle is designed for easy transport and for storage in tight spaces.

Hawk offers 13", 15", 17" & 20" sizes and 1500, 1800 & 2000 RPM speeds. Select the Active Dust Control model for Green Cleaning programs.

Power

- 1.5 HP, 66 frame, DC rectified motor. 115V, 50/60 Hz power. 230V optional.
- 50 ft. 14-3 STO industrial power cord with molded plug
- Order 1500, 1800 and 2000 RPM model with belt-drive

Engineered Design

- Welded, heavy gauge industrial powder coated steel frame
- Variable position positive lock handle with dipped vinyl grips
- Steel pad covers with 360 degree wraparound bumper
- Dust control on 17" and 20" models
- Thumb operated safety switch. Negative pressure on/off switch.
- Dual steel operating triggers
- 1" x 5" non-marking ball bearing wheels
- Includes flexible pad holder with pad centering clamp

Safety Features

- Quiet operation - 69 dB (high speed), 62 dB (high speed with Dust Control). Meets GS42 requirements
- UL/CUL listed



Specifications

Machine Pad Size	13" Standard 13"	15" Standard 15"	17" Standard 17"	17" Dust Control 16"	20" Standard 20"	20" Dust Control 19"
Speed	1500 RPM					
Model #	HCF1513-1500	HCF1515-1500	HCF1517-1500	HCF1517-1500DC	HCF1520-1520	HCF1520-1520DC
Part #	F1500-13CF	F1500-15CF	F1500-17CF	F1500-17CFDC	F1500-20CF	F1500-20CFDC
Amp Draw	11.4 Amp	11.9 Amp	12.6 Amp	13.2 Amp	12.6 Amp	13.2 Amp
Speed	1800 RPM					
Model #	HCF1513-1800	HCF1515-1800	HCF1517-1800	HCF1517-1800DC	HCF1520-1820	HCF1820-1520DC
Part #	F1800-13CF	F1800-15CF	F1800-17CF	F1800-17CFDC	F1800-20CF	F1800-20CFDC
Amp Draw	11.7 Amp	12.3 Amp	13.2 Amp	13.9 Amp	13.2 Amp	13.9 Amp
Speed	2000 RPM					
Model #	HCF1513-2000	HCF1515-2000	HCF1517-2000	HCF1517-2000DC	HCF1520-2020	HCF1520-2020DC
Part #	F2000-13CF	F2000-15CF	F2000-17CF	F2000-17CFDC	F2000-20CF	F2000-20CFDC
Amp Draw	11.8 Amp	12.5 Amp	13.8 Amp	14.8 Amp	13.8 Amp	13.8 Amp

All Models

Motor / Power	66 frame, 1.5 HP, rectified DC motor. 50/60 Hz power. 230V available.					
Power Cord	50 ft. (14-3) STO power cord with molded plug. 75 ft. (12-3) cord available.					
dB Rating	69 dB	69 dB	69 dB	62 dB	69 dB	62 dB
Machine Weight	84 lbs.	86 lbs.	88 lbs.	90 lbs.	90 lbs.	92 lbs.



Stripping, Scrubbing, Buffing



The BlackHawk has been redesigned for easy transport in today's smaller vehicles. The exclusive Pin-Set™ Handle Lock does away with nuisance adjustments that are common with friction handle locks. Steel construction with commercial-quality components include ball bearing wheels, commercial grade cord and grips, a solid steel handle lock and the durable 1.5 HP dual-capacitor motor. The BlackHawk buffer can deliver 24/7 reliable results for years to come.

Power

- 1.5 HP, 66 frame, rectified dual capacitor motor
- 115V, 60 Hz power. 50 ft. 2-piece 14-3 SJT power cord with molded plug

Drive System

- Triple-planetary 10:1 helical-cut commercial gears drive pads and brushes at 175 RPM

Engineered Design

- The all steel detachable handle with pin-set handle lock disassembles in 60 seconds, no tools required.
- Quality welded steel construction
- Pin Set™ Handle Lock adjusts the handle to 4 heights
- 17" or 20" brush covers. 360 degree wraparound bumpers.
- Thumb-operated safety switch. Dual steel operating trigger.
- Negative pressure on/off switch
- Optional 4 gallon solution tank in 5 stock colors
- Optional Splash Guard (#SPLASH17) or (#SPLASH20)
- Sturdy 1" x 5" non-marking ball bearing wheels
- Includes Hawk Lok™ molded plastic pad driver

Safety Features

- Quiet 62 dB operation. Meets GS42 standard.
- Built with UL approved components



Specifications

Model #	BLKHWK17	BLKHWK20
Part #	F0009-BH2P	F0012-BH2P
Machine Size	17"	20"
Pad Size	16"	19"
Pad Speed	175 rpm	175 rpm
Amp Draw	5.9 Amp	6.5 Amp
Weight	103 lbs.	106 lbs.

All Models

Motor	66 frame, 1.5 HP rectified DC motor
Power	115V / 60 Hz (230V Option)
Power Cord	50 ft. 14-3 STO power cord with molded plug
Drive System	Triple-planetary 10:1 helical-cut gears
dB Rating	62 dB - Meets GS42 standard

Subject to Change Without Notice



Remove/Install the Handle in 60 Seconds



Exclusive Pin-Set™ Handle Lock - 4 Height Settings



Remove the Handle Mounting Pin w/o Tools



Includes Hawk Lok™ Pad Driver



Burnishing, Refinishing



The BlackHawk 1250 Burnisher drives a 20" pad at 1250 RPM for efficient polishing of all hard floor finishes. The 1.5 HP TEFC (Totally Enclosed Fan Cooled) AC motor is powerful, and is built with a motor shroud that protects the inner workings from dust and moisture. The welded steel frame and chromed handle are durable and reliable. The 1250 is remarkably easy to handle.

Power

- 1.5 HP, 56C frame, TEFC dual capacitor AC motor
- 115V, 60 Hz power
- 50 ft., 14-3 STO power cord with pig-tail

Drive System

- V-Belt drives pads at 1250 RPM

Engineering Design

- Welded heavy gauge steel frame
- One piece chromed heavy duty steel handle
- Molded plastic pad cover with wraparound bumper
- Thumb-operated safety switch
- Comfortable dipped vinyl grips
- Negative pressure on/off switch
- Dual steel operating triggers
- Multiple position handle adjustment
- 1" x 5" non-marking ball bearing wheels
- Includes style flexible pad driver with spring-style pad centering clamp (#KIT2014)

Safety Features

- Quiet operation - 58 dB. Meets GS42 standard.
- Built with UL listed components



Specifications

Model	BlackHawk 1250
Part#	F56-20-02
Motor	56C frame, 1.5 HP TEFC dual capacitor AC Motor
Drive System	Multi V-Belt Drive
Power	115V, 60 Hz power
Cord	50 ft. 14-3 STO power cord with molded plug
Pad Size	20"
Pad Speed	1250 RPM
Construction	Steel frame, molded plastic brush cover
Amp Draw	11.2 Amp
dB Rating	58 dB - Meets GS42 Standard
Weight	90 lbs.

Subject to Change Without Notice



All Steel Construction
Handle, Frames



Flexible Pad Driver



Use with 20" Hogs Hair
Pads and Centering Clamp



Two-Part
Power Cord



Burnishing, Refinishing



The BlackHawk 1500 Burnisher drives a 20" pads at 1500 RPM for efficient polishing of all hard floor finishes. The 1.5 HP 66 frame DC motor is powerful. The welded steel frame and 2-piece powder-coated handle are durable and reliable.

Power

- 1.5 HP, 66 frame, DC rectified motor
- 115V, 60 Hz power
- 50 ft., 2-part (14-3) STO industrial power cord w/ pig-tail end
- V-Belt drives pads at 1500 RPM

Engineering Design

- Welded heavy gauge steel frame
- Two-piece powder coated, heavy duty steel handle
- Molded plastic pad cover with wraparound bumper
- Thumb-operated safety switch.
- Negative pressure on/off switch
- Dual steel operating triggers
- Comfortable vinyl-dipped foam handle grips
- Pin lock handle adjustment
- Non-marking 1" x 5" non-marking ball bearing wheels
- Includes harpoon style flexible pad driver with spring-style pad centering clamp (#KIT2014)
- Private brand colors; Black, Hammer-Silver, Red, Orange, Light Blue, Medium Blue, Yellow and Chrome

Safety Features

- Quiet operation - 66 dB. Meets GS42 standard.
- Built with UL listed components



Specifications

Model	BlackHawk 1500
Part#	F57-1500
Motor	1.5 HP, 66 frame DC rectified motor
Drive System	Multi v-belt drive
Power	115V, 50/60 Hz power
Cord	50 ft.,14-3 STO power cord with pig tail end
Pad Size	20"
Pad Speed	1500 RPM
Amp Draw	15.5 Amp
dB Rating	66 dB - Meets GS42 standard
Weight	92 lbs.

Subject to Change Without Notice



Harpoon Style Pad Driver with Pad Centering Clamp



All Steel Construction Handle, Frames



Pull the Pin for Easy Handle Removal



Dry Floors, Circulate and Exhaust Air in Smaller Jobs



**HAWK BVP25D
900 CFM Air Mover**



The new Hawk BVP25D air mover is designed for small to medium size jobs. Ideal for ventilating hard to reach areas using its robust 1/4 HP induction motor and choice of three air flow positions. The 3-speed motor moves air up to 900 CFM.

Two 12 Amp auxiliary power outlets on the side-mounted control panel makes it easy to connect up to 5 unit in daisy chain operation. Quiet - 67 dB.

Engineered Design

- 3-Speed, 1/4 HP motor with a 10 ft. 14 AWG power cord. The switch and circuit breaker are located on the control panel.
- Up to 900 CFM air flow
- Two 12 Amp grounded auxiliary power outlets on the side-mounted control panel
- Use daisy chain in-line connection of up to 5 units for more effective, focused air flow
- Strong roto-molded chassis has a profile that allows for vertical stacking of up to 5 units for convenient storage
- Ergonomic handle for easy transport
- Lightweight 11.3 lbs.
- Quiet operation - 67 dB
- C-ETL-US certification
- 5 year warranty on rotomolded chassis. 2 year warranty on parts.

Specifications

Model	BVP25D
Motor	1/4 HP, 115V, 60Hz
Air Volume	900 CFM (High), 700 CFM (Med), 690 CFM (Low Speed)
Amp Draw	2.1 Amp (High), 1.8 Amp (Med), 1.7 Amp (Low Speed)
Air Flow Direction	0, 45 and 90 degrees
Max Static Pressure	1.3"
Frame Construction	Sturdy Rotomolded Plastic
Stackable	5 units
Daisy Chain	Yes - Up to 5 Units
Weight	11.3 lbs. (net) / 12.6 lbs. (gross)
Size (LxWxH)	12.8" x 12.4" x 13.3"
Attached Cord	10 Ft. 14 AWG
Sound Level	67 dB
Certification	C-ETL-US

Subject to Change Without Notice



Side Mount
3-Speed Switch and
Dual 110V Power Outlets



Daisy Chain up to
5 Units for Extra Air
Moving Power



Air Flow in 3 Angles
0, 45 & 90 Degrees



Works in Tight Spaces for
Tough Drying Jobs



Dry Floors, Circulate and Exhaust Air

The Hawk BVP50 is the safest and most efficient centrifugal air mover on the market. Our 1/2 HP motor powers an airflow up to 2820 CFM with just 4.5 amps usage.

Control the air flow and amp draw with our state of the art 2-speed moisture resistant switch. The rotationally molded body is strong, lightweight and easy to transport, clean and easy to stack. The BVP50H model adds a telescoping handle frame with transport wheels.

Engineered Design

- The 1/2 HP, 2-Speed motor is efficient and produces up to 2820 CFM airflow
- 25 ft. 16 AWG power cord
- The motor is sealed to prevent moisture from entering and damaging internal motor components
- The side-mounted 2-speed switch is moisture resistant
- Sturdy roto-molded plastic frame design has a profile that allows for vertical stacking up to 4 units for convenient storage
- The **BVP50** multipurpose design directs air at 3 angles (horizontally, 45° and 90°)
- The **BVP50H** adds a telescoping handle and transport wheels. Use horizontally, or tip back 90 degrees and move air straight upward.
- A plastic cage protects motor and fans from debris
- C-ETL listed
- 2 year warranty on parts. 5 year warranty on rotomolded chassis.



HAWK BVP50
2820 CFM Air Mover



HAWK BVP50H
with Handle and
Transport Wheels



Specifications

Model	BVP50, BVP50H (with Telescoping Handle & Wheels)
Motor	1/2 HP, 115V, 60Hz
Air Volume	2820 CFM (High Speed) / 2390 CFM (Low Speed)
Amp Draw	4.5 Amp (High Speed) / 2.8 Amp (Low Speed)
Max Static Pressure	2.5"
Air Flow Direction	0, 45 and 90 degrees
Frame Construction	Sturdy roto-molded plastic
Stackable	4 units
Weight	25 lbs. (net) / 28 lbs. (gross)
Size (LxWxH)	22.5"x 20"x 13"
Attached Cord	25 Ft. 16 AWG
Sound Level	74 dB
Certification	C-ETL-US

Subject to Change Without Notice



Store Up To
5 Stacked Units



BVP50H Adds Dual
Transport Wheels and
Telescoping Handle



Direct Airflow at 3 Angles
(Horizontally, 45° and 90°).



Compact Air
Moving Power



Dry Floors, Circulate & Exhaust Air

The HAWK Industrial Air Mover with 1/2 HP, 3-speed industrial motor moves air up to 2950 CFM. Built with super-tough polypropylene housing for long-term use in construction, manufacturing and housekeeping. The metal cage mounted on the housing adds discharge safety.



Moves Air at 3 Angles

Power

- 0.5 HP, 3-speed motor
- 115 V, 50/60 HZ power. 230V available.
- 35 ft., 2-part, (16-3) SJTOW power cord with molded plug
- Top-mounted quick change 3-speed switch

Engineered Design

- Three air flow speeds - 2000, 2500 and 2950 CFM. Moves up to 50 ft. at high speed.
- Speed switch is conveniently located next to lifting handle
- Continuous-duty rugged ball bearing motor
- Roto-molded polyethylene housing with lifetime warranty
- Plastic fan wheel
- Steel handle and discharge guard
- 8 rubber feet for non-slip positioning
- Stackable for easy storage
- Convenient size - 19.5" x 14.5" x 18.25"

Safety features

- Quiet operation with dB sound levels: Low speed 59 , Medium 62, High speed 64. Meets GS42 standard.
- UL -listed.



Specifications

Model	BH001		
Part Number	BH001-02 (BLK), BH001-08 (BLU)		
Motor	0.5 HP, 3-Speed 110V motor		
Motor CFM	2950 CFM	2500 CFM	2000 CFM
Amp Draw	5.3 Amp	4.5 Amp	4.3 Amp
Power Cord	35 ft., 2-Part, (16-3) SJTOW Power Cord		
Housing	Roto-Molded Machine Housing		
Positions	Directs Air at 0, 45 and 90 Degrees		
dB Rating	59 dB (low speed), 62 dB (medium), 64 dB (high) Meets GS42 Standards		
Machine Size	19.5" x 14.5" x 18.25"		
Ship Size	20" x 20" x 20"		
Weight	31 lbs.		

Subject to Change Without Notice



Moves Air Up to 60 ft. at High Speed



Compact Power 19.5" x 14.5" x 18.25"



Metal Carrying Handle



HAWK BH25AD Axial
1720 CFM Air Mover

Dry Floors, Circulate and Exhaust Air

The Hawk BH25AD Axial Air Mover produces up to 1720 CFM airflow with a variable control dial switch. The low amp draw and dual built-in 12 amp power outlets allows for multiple units to be used in daisy chain.

The metal rack/stand provides 360 degree rotation for multiple positions when drying surfaces or circulating air.

The specially designed blades and fan grille excel in extending a powerful and focused straight stream of air up to 60 feet.

Power

- 1/4 HP motor, 115V / 60 Hz.
- A sealed motor design prevents moisture from entering and damaging internal motor components
- 20 foot power cord
- 6 month motor warranty

Engineering Design

- Axial design is efficient and produces up to 1720 CFM
- 360 degree adjustable positions
- Injection molded housing is lightweight and durable
- Two 12 Amp GFCI grounded auxiliary power outlets on the side-mounted control panel. These outlets allow for daisy chain in-line connection of up to 3 units for more effective air flow.
- GFCI outlets on the control panel reduce the risk of electric shock in wet areas and is required by insurance companies paying for water flood cleanup claims

Safety Features

- Environmentally responsible. ETL/CETL Listed
- Sound level - 78 dB



Specifications

Model	BH25AD
Motor	1/4 HP, 115V, 60Hz
Air Volume	Adjustable 0 to 1720 CFM
Amp Draw	Up to 2 Amp
Auxiliary Outlet	12 Amp with Circuit Breaker
Max Static Pressure	2.5"
Fan Blade	(3) 16" ABS Molded Plastic Blades
Frame Construction	Injection Molded Chassis
Weight	16 lbs. (net) / 28 lbs. (gross)
Size (LxWxH)	39"x 13"x 35"
Attached Cord	20 Ft. 16 AWG

Subject to Change Without Notice



Stackable Chassis
for Storage Only



Direct Air at Every Angle

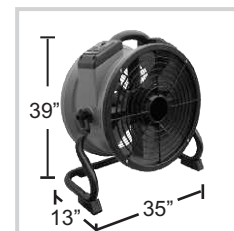

Moves Air Up To
60 Feet

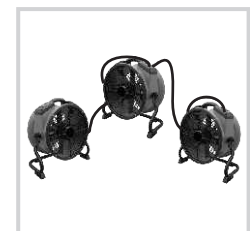

Move More Air with Daisy
Chained Power



**HAWK BPB25DA Axial
3320 CFM Air Mover**



Dry Floors, Circulate and Exhaust Air

The Hawk BPB25A Axial moves air efficiently with less power and effort than other models. A built-in GFCI Auxiliary Outlet* reduces risk of electric shock in wet areas. The BPB25A shoots a beam of air 50 feet ahead. An optional mounting stand locks onto the chassis and allows for 360 degree rotation to move air in any direction.

*Required for use when Insurance Companies are paying for water and flood cleanup claims

Engineered Design

- 2-Speed, 1/4 HP motor. A sealed motor design prevents moisture from entering and damaging internal motor components. 25 ft. 14 AWG foot power cord
- Axial design is efficient and produces up to 3320 CFM
- The metal air intake screen prevents objects from entering and damaging blades or motor
- Two 12 Amp GFCI grounded auxiliary power outlets on the side-mounted control panel. GFCI reduces the risk of electric shock in wet areas and is required by insurance companies paying for water flood cleanup claims.
- Use daisy chain in-line connection of up to 5 units for greater and more effective air flow
- 2-speed toggle switch with LED light on/off indicator
- Hour meter on control panel tracks hours of operation
- Strong roto-molded chassis has a profile that allows for vertical stacking of up to 5 units for convenient storage
- An optional folding metal frame with quick release locking knob allows easy adjustment for 360 degree airflow direction
- C-ETL US listed
- 2 year warranty on parts. 5 year warranty on the roto-molded chassis.

Specifications

Model	BPB25DA Axial
Motor / Power	1/4 HP, 2-Speed, 115V, 60 Hz, Sealed Motor
Motor CFM	3320 CFM Max
Amp Draw	2.6 Amp (High Speed), 1.3 Amp (Low Speed)
Power Cord with Molded Plug	25 Ft. 14 AWG
Air Flow	360 degrees
Meters	Timer, LED PowerYes
Size (H x W x L)	20" x 13" x 22.5"
Construction	Sturdy Rotomolded Plastic
Stackable	5 units
Daisy Chain	Yes - Up to 5 Units
Size (L x W x H)	22.5" x 13" x 20"
Weight	30 lbs. (net) / 34 lbs. (gross)
Sound Level	78 dB
Certification	C-ETL-US

Subject to Change Without Notice



The Chassis is Rotomolded with a Profile for Stacking and Convenient Storage



Add the Folding Metal Frame to Direct Air at Every Angle



(2) GFCI Outlets and Convenient 2-Speed Switch



GFCI Shock-Preventing Outlets Make Daisy Chain Connection Easy



Small to Large Area Vacuum Cleaning

The Hawk V20, 20 gallon tank vacuum is built for years of trouble-free service. Ideal for recovery of liquids and solid wastes in all size cleanup jobs. Rugged and durable for the professional market. Non-corrosive tank with large 12.5" top access makes dump and discard easy. Empty larger flowing liquid jobs with the 1.5" hose (included). Available with optional front mount squeegee for even easier results.

Power

- 2 HP, 2-stage heavy duty bypass motor. (230V Option).
- 35 ft. (16-3), 2-part power cord

Engineered Design

- Non-corrosive tank with large 12.5" top access.
- The tank is sized to hold a 5 gallon pail. Great for collecting and cleaning viscous liquids and slurries.
- Large 5" rear wheels and strong 3" front casters
- Powder-coated steel handle and carriage
- An automatic liquid shut-off prevents motor flooding
- Includes 15 ft. flexible vacuum hose (#HPWT1060)
- Includes wet/dry tool kit (#HPVA002)
- Includes washable synthetic cloth dust bag (#HPWDH0001ASSY)
- Optional 30" front-mount squeegee (#HPV006FMS)

Safety Features

- Quiet operation - 68 dB. Meets GS42 requirements
- 1.5" quick drop drain hose prevents need for lifting
- UL / CUL Approved components for safe performance



V2
Wet/Dry
Tank Vacuum



Includes:
Wet/Dry Tool Kit
#HPVA002

15' Flexible
Vacuum Hose
#HPVT1060



ELKHART, IN



SPECIFICATIONS

Model	V20
Capacity	20 gallon
Wet Pick Up	16 gallons
Dry Pick Up	1.5 bushel (14 gallons)
Motor	2 HP DC, 2-Stage
Power	115V, 50/60 Hz
Amperes	10.7 Amp
Power Cord	35 ft., 2-Part, 16/3 cord
Water Lift	117 inch
Air Flow	112 CF
Wheels	(2) 6" rear, (2) 3" front
Weight	62 lbs.
Drain Valve	1.5 inch
Dimensions (HxDxW)	37" x 24.25" x 24"
Sound Levels	68 dB

Subject to Change Without Notice



Optional 30" Front
Mount Squeegee
#HPV006FMS



Washable Cloth
Vacuum Bags
#HPWDH0001ASSY



Compact Tank
Vac Design



Accepts Your 5 Gallon
Pail for Collecting
Slurry Liquids



Large Area Vacuum Cleaning



Titan 29 & Titan 55



Includes:
Wet/Dry Tool Kit
#HPVA002

15' Flexible
Vacuum Hose
#HPVT1060



The Hawk Titan 29 and Titan 55 wet/dry tank vacuums are built for years of trouble-free service. Ideal for large volume recovery of liquids and solid wastes. Safely moves heavy loads up to 400 lbs. on large rear wheels and industrial front casters. The corrosion-resistant tank is easy to rinse out through the 13" top entry hole. Drain liquids and debris collections from the rear-mounted quick-drop drain valve.

Power

- 2 HP, 2-stage heavy duty bypass motor. (230V Option).
- 2-piece commercial, 35 ft. (14-3) SJT easy-wrap power cord

Engineered Design

- Corrosion-resistant roto-molded tank is easy to clean
- Quick-drop drain valves - 1.5" (T29) and 3" (T55)
- V29-V - Large 5" rear wheels and strong 3" front casters
- V55-V - Large 6" rear wheels and strong 4" front casters
- Powder-coated steel handle and carriage
- An automatic liquid shut-off prevents motor flooding
- Includes wet/dry tool kit (#HPVA002)
- Includes 15 ft. flexible vacuum hose (#HPVT1060)
- Includes one acid and mildew resistant, non-pleated washable synthetic cloth dust bag (#HPVA4040) and mounting ring (#VA2018)

Safety Features

- Quiet operation - 68 dB. Meets GS42 requirements
- Quick drop drain hose prevents need for lifting
- UL / CUL approved components for safe performance

SPECIFICATIONS

Model #	Titan 29	Titan 55
Part #	V29-V	V55-V
Capacity	29 gallon	55 gallon
Wet Pick Up	22 gallons	48 gallons
Dry Pick Up	2 bushel (18.6 gal)	4 bushel (37.2 gal)
Motor	2 HP DC, 2-Stage	2 HP DC, 2-Stage
Power	115V, 50/60 Hz	115V, 50/60 Hz
Amperes	10.7	10.7
Power Cord	35 ft., 2 Part, 16/3	35 ft., 2 Part, 16/3
Water Lift	117 inch	117 inch
Air Flow	112 CFM	112 CFM
2 Wheels - Rear	8 inch	10 inch
2 Casters - Front	4 inch	5 inch
Weight	80 lbs	94 lbs
Drain Valve	1.5 inch	3 inch
Dimensions (HxDxW)	40" x 33.5" x 20.5"	45" x 38" x 25.5"
Sound Levels	68 dB	68 dB

40"



Titan 29 Tank Vacuum

45"



Titan 55 Tank Vacuum



Quick-Drop Drain Valves - 1.5" (V29) and 3" (V55)



Wheels, Casters & Molded Tank are Mounted on Strong Steel Frame

Subject to Change Without Notice



Portable Vacuum Cleaning

Carry vacuum cleaning power on your shoulders. The top fill design on this lightweight, compact backpack vac prevents clogging, so you can optimize your cleaning time. The 6.5 quart tank capacity extends operating time. The large area triple-filtration design keeps dirt in the canister and out of the air. The ergonomic construction of this 10.5 lb. vacuum makes it ideal for cleaning any size areas.

Power

- 1-Stage motor with thermal protection
- 2-piece commercial, 50 ft., (14-3) SJT easy-wrap power cord

Engineered Design

- Roto-molded polyethylene housing is tough, durable and easy to clean. Lifetime housing warranty.
- Lightweight - 10.5 lbs. machine reduces user fatigue
- Hold the backpack on your back with a comfortable harness and padded shoulder straps. Quick-lock adjustable strap fasteners make it easy to wear.
- Exceptional filtration capability. The Harrier captures fine particles and helps improve air quality.
- 8 rubber feet for maximum, diffused air exhaust
- Use the disposable paper filter bags (#HPVA005-3) or washable cloth filter (#HPV-BACK-CLTH-BAG)
- Complete tool kit includes flex hose, telescopic wand, 1-piece curved wand, round dusting brush, two-way flat floor tool for hard and soft floor and floor crevice.

Safety

- 72 dB quiet operation
- UL Listed



Harrier 1



Specifications

Model	Harrier I
Part Number	V001-H1-115
Motor	1 stage, 1120 Watt motor
Power	115V, 50/60 Hz power. (230V option).
Power Cord	50 ft. 16-3 SJT power cord w/molded plug
Amp Draw	7.0 Amp
Water Lift	96"
Air Flow	144 cfm
Housing	Roto-Molded Polyethylene
Size	8" x 9" x 21"
Tools	4 tools plus 2 piece curved wand
dB Noise Rating	72 dB
Weight	10.5 lbs. with cord

Subject to Change Without Notice



Powerful 1-Stage Motor

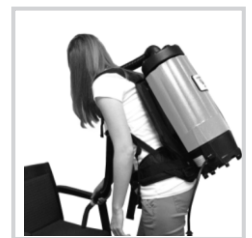

Lightweight Power



Disposable Paper Vacuum Bags #HPVA005-3



Washable Cloth Bags #HPV-BACK-CLTH BAG



Portable Extraction Cleaning

The Mini-Vactor is more than an ordinary spotter. This affordable, powerful, compact unit is designed for superior carpet and upholstery cleaning. The model with in-line water heater makes cleaning faster.

Power

- 1 HP, 2-Stage vacuum motor. 110V, 50/60 Hz.
- 13 Amp, 700 W in-line water heater in EXT-3H model
- 3-setting power switch
- 25 ft., 14-3 STO power cord with molded hanger

Engineered Design

- 3.1 gal. solution tank. 3.5 gal. recovery tank.
- 45 psi oscillating vacuum pump
- Two aluminum locks hold the solution tank to the recovery tank
- Float ball shut-off in the recovery tank protects the vacuum motor from water damage
- Spin-off cover on the lift-off recovery tank makes cleaning and rinsing easy
- 3-position switch allows the operator to choose from the pre-spray mode with no vacuum, spray and vacuum mode, and the vacuum only mode
- Includes 8 ft. vacuum and solution hoses
- Includes 4" stainless steel hand wand
- Optional 2-piece, stainless-steel wand with 10" head, 10 ft. vacuum hose and solution hose

Safety Features

- Quiet operations - 58 dB. Meets GS42 requirements



Specifications

Model	Hot Shot Mini Vactor w/ Heat	Hot Shot Mini Vactor w/o Heat
Part Number	EXT-3H	EXT-3NH
Amp Draw	13 Amp	8.5 Amp
Heater Power	700 W, 130 degrees F	--
Both Hot Shot Machines		
Solution Tank	3.1 Gallons	
Recovery Tank	3.5 Gallons	
Power	115V, 60 Hz, 3-Position Power Switch	
Water Lift	85 inch	
Solution Pump	Oscillating Type, 45 PSI	
Power Cord	25 ft., 16/3	
dB Rating	58 dB - Meets GS42 Standard	
Chassis	Roto-Molded Poly with Handle	
Size	9"W x 18"T x 20"L	
Weight	27 lbs (Extractor, Wand, Hose, Power cord)	

Subject to Change Without Notice



Optional Vacuum Wand Set
#EXTCR-WAND-10SS



Lift-Off Recovery Tank



3.1 Gallon Solution Tank is Easy to Fill



3.5 Gallon Recovery Tank is Easy to Empty and Rinse



For Spray Application of Floor Chemicals



The Hawk Osprey Pro 2G Backpack Sprayer helps the user apply cleaning products, surface protectants, dyes and densifying agents with speed and accuracy. The commercial-duty “No-Leak” sprayer is designed with tight specifications and with corrosion resisting materials.

Padded straps are adjustable for comfortable use by personnel of all sizes. A top mounted carrying handle and wide base assists in transport and mounting on the operator’s shoulders.

Engineered Design

- Internal “No Leak” piston pump is safer to use
- Durable, 21 in. poly-lined stainless steel wand with the highest quality Viton® seals is chemical resistant
- A continuous spray switch can lock the nozzle to the “on” position. Convenient for larger jobs.
- Premium, lockable shut-off valve with brass components and an in-line filter
- The pump is easy to access. Change seals in just minutes without tools.
- Includes 4 nozzles to select spray pattern; brass adjustable 2 flat fans, and foaming nozzle.
- Padded backpack style straps allow the operator to comfortably carry the sprayer
- Sturdy carrying handle and wide balanced base



21” Poly Wand with Viton® Seals



Includes Four Nozzles to Produce Ideal Spray Pattern



Heavy-Duty Padded Shoulder Straps Fits Operators of Every Size



Change Handle Mount for Left or Right Hand Pumping

Specifications

Model	Osprey Pro 2G
Part Number	F-OP2G
Tank Capacity	2 Gallons
Tank Construction	Heavy-Duty Roto-Molded Poly
Frame Construction	Polished Lightweight Aluminum
Pump Pressure	Up to 150 PSI
Sprayer Wand	21” poly lined stainless steel

Subject to Change Without Notice



Large Area Floor Finish Applicator

The HAWK Flight Applicator glides across the floor as it applies both water-based and solvent-based finishes, restorers and disinfectants in a smooth, even, crystal-clear coat.

Available with 3 aluminum applicator head sizes - 28", 36" and 48" wide - delivering solutions to the floor at up to 27,500 square feet per hour. The patented, variable-flow control pump can reduce finish usage by up to 20%.

No spills, no drips, no baseboard splashes. Even novice users can perform like a pro.

Hawk Engineering

- 12 V battery-powered 70 psi solution pump delivers finishes to the floor through a 28", 36" or 48" aluminum applicator bar
- Patented variable flow control switch and a master on/off switch is at your finger tips
- 8" wheels with a magnetic sensor activates the pump as you pull the Flight Applicator across the floor
- Use a lambs wool applicator with added 3" synthetic yarn to spread solvent-based finishes
- Use a microfiber applicator pad to apply water-based finishes. (Always check the finish product label for the recommended pad type.)
- Pads easily mount to the applicator bar with harpoon hooks
- The corrosion-resistant, powder-coated frame is 21" wide x 33.5" deep and holds (2) 5 gallon bottles
- A pin-locked handle fits the user's height, adjusting from 32" to 40" high
- Easy to rinse and clean. The applicator bar and pad disconnects for convenient storage.



Lambs Wool Pad with Synthetic Finish-Spreading Yarn

Microfiber Pad



Specifications

Model	Flight 28	Flight 36	Flight-48
Part Number	F-HF-28	F-HF036	F-HF-48
Aluminum Head Size	28"	36"	48"
Application per Hour	15,000 sq.ft.	20,000 sq.ft.	27,500 sq.ft.
Pump / Motor	70 PSI		
Frame Construction	Corrosion-resistant, Powder Coated Steel Frame		
Frame Dimension	21.2" x 21" x 33.5"		
Adjustable Handle	32" to 40" High		
Pad with Twisted Synthetic Yarns			
(1) Microfiber Pad	#HVMVP28	#HVMVP36	#HVMVP48
(1) Lambs Wool	#HVLWP28	#HVLWP36	#HVLWP48
Warranty	1 Year Pump and Motor - 3 Years Steel Frame		

Subject to Change Without Notice



Battery Powered Pump Moves Finishes from Pail to Floor



Pin-Lock Handle Adjusts from 33" to 40" High



28", 36" & 48" Microfiber Pads with Hook & Loop Mounting



28", 36" & 48" Lambs Wool / Yarn Pads Fit on Applicator Bar



Spotting, Tight Spaces, Baseboards, Stairs

The Talon Edger Floor Machine is designed to scrub built-up dirt in corners and on baseboards without bending and back-breaking effort. Scrub with pads or with optional bonnets or brushes. Includes the pad driver and an assorted pad startup kit.

Power

- 1/8 HP, DC motor. 115V, 50/60 Hz power.
- 35 ft. 2-pc., (14-3) SJTOW power cord with molded plug

Drive System

- Enclosed, durable gear belt drives brushes and pads at 500 RPM

Engineered Design

- 2 sizes - 6" and 8" diameter brushes and pads
- Handle height adjusts from 47" to 52" with locking pin
- Roto-molded polyethylene housing
- The metal handle folds over for easy transport and storage
- The brush drive is injection molded and reinforced with resin. The unique Mag-Lok™ magnetic system securely mounts brushes and pad drivers to the brush drive without tools
- Optional bristle brushes, pad fibers and bonnets

Safety Features

- Quiet operation
- Built with UL approved components



Red Scrub
6" AS009-CS
8" AS009-8CS

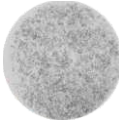

White Polish
6" AS011-CS
8" AS011-8CS



Black Strip
6" AS010-CS
8" AS010-8CS



Pad Driver (1)
6" AS003
8" AS003-8

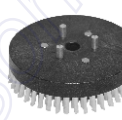

Nylon (1)
6" AS002
8" AS002-8



Grit (1)
6" AS005
8" AS005-8



Nylon Edger (1)
6" AS006
8" AS006-8



Grit Edger(1)
6" AS001
8" AS001-8



Bonnet (6)
6" AS008-6
8" AS008-8

Specifications

Model	Talon-6	Talon-8
Part Number	F06-06-02	F06-08-02
Brush Size	6"	8"
Machine Dimension	6"x11"x47" Adjusts to 52"	8"x11"x47" Adjusts to 52"
Weight	10.5 lbs.	10.5 lbs.
Specifications Both Machines		
Motor	1/8 HP, 115V DC	
Power	115V, 60 Hz 1.1 Amp draw.	
Power Cord	2-Part, 35 ft. (16-3) SJT	
Brush Speed	500 RPM	
Brush Mount	Mag-Lok™	
Housing	Molded high density plastic	



Talon Scrubs in Tight Spaces

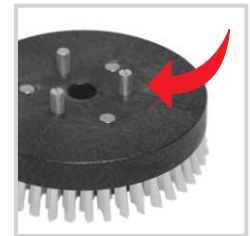

Mag-Lok™ 3 Steel Drive Pins Mount Brushes & Pad Driver



Adjustable Handle Height Locks to Position



Talon Tools Strip, Scrub & Polish



Scrub and Polish Tight Spaces - 12", 14" and 16"



The Hawk Twin Talon was born out of need for affordable compact power. Dual 1/8 HP motors spin twin heads at 500 RPM in opposing direction. The result is a very controllable polisher with a low center of gravity.

The Twin Talon is small enough to work on counter tops but large enough to polish a small bathroom floor. Available in three sizes. The 36" removable handle (optional) mounts over the hand grips and lets you stand while using the Twin Talon as an edger, carpet spotter and a floor scrubber.

Engineered Design:

- Compact 22.5 lbs. design.
- 3 sizes (12", 14", & 16")
- The 14" model is designed for use with diamond tools, mounted with pad driver (#AS003-7)
- 1/8 HP dual motors
- Add the optional 36" easy-mount handle for use while standing
- Exclusive Mag-Lock™ brush and driver attaching system
- Durable resin cover is mounted over a steel frame for reliable performance
- Quiet belt-drive power
- Simple operator switch for both hand or foot operation
- 2-piece commercial, 35 ft. (16-3) SJT easy-wrap power cord
- Optional easy-mount handle (#KIT3062)
- Wide selection of drivers & specialty brushes
- UL / CUL Approved components for safe performance

Optional
Easy-Mount Handle
#KIT3062



Red Scrub
6" AS009-CS
8" AS009-8CS



White Polish
6" AS011-CS
8" AS011-8CS



Black Strip
6" AS010-CS
8" AS010-8CS



Pad Driver (1)
6" AS003
8" AS003-8



Nylon (1)
6" AS002
8" AS002-8



Grit (1)
6" AS005
8" AS005-8



Nylon Edger (1)
6" AS006
8" AS006-8



Grit Edger(1)
6" AS001
8" AS001-8



Bonnet (6)
6" AS008-6
8" AS008-8

Specifications

Model	Twin Talon 12	Twin Talon 14	Twin Talon 16
Part #	#F86-12	#F86-14	#F86-16
Pad Size	6"	6"	8"
Brush Size	6"	6"	8"
Motor	1/8HP DC Rectified, 115V, 50/60 Hz		
Brush Speed	Dual Belt Drive, 500 RPM		
Power Cord	2-Part, 35 ft. (16-3) SJT		
Amp Draw	5.0 Amp	5.5 Amp	6.0 Amp
Weight	22.5 lbs.	22.5 lbs.	22.5 lbs.



Hand Polishing of
Hard Surfaces



Carpet Spotting
and Detail



Tight Space Cleaning

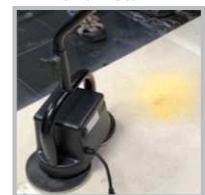

Hard Surface
Polishing



Polish Stone and Concrete Floors with a 1.5 HP Severe-Duty Floor Machine

The Hawk Claw Diamond Pad Driver provides peak grinding and polishing results to the natural stone and concrete tradesman. The Claw is available in five sizes - 10", 13", 15", 17" and 20", driving both 3" round tools, and trapezoidal tools.

Tools are held in milled recesses in the Claw plate with the unique Mag-Lok™ industrial magnet system. Grinding and polishing tools mount securely on the plate, yet are easy to change without tools.

Operating vibrations are reduced by Neoprene rubber vibration damping isolators built into the mounting system with a custom milled aluminum clutch plate. Power the Claw with your severe-duty 1.5 HP rotary floor machines.

Engineered Design:

- The weighted Claw plate is built with 3/8" plate steel, powder-coated for corrosion resistance and easier clean up
- The face of the Claw plate is milled with round and trapezoidal tool mounting recesses, each fit with a Mag-Lok industrial magnet
- The top of the Claw plate is fit with a custom milled aluminum NP9200 clutch plate, sitting on top of six 1" Neoprene rubber vibration isolators. These isolators reduce vibration and flex over high points and lippage.
- Round 3" resin tools mount securely on a 3" metal adaptor plate with hook and loop face. The adaptor and tool combination mounts onto the Claw plate recess with the Mag-Lok system. Order tools separately.
- The 17" and 20" Claw plates add hand grab holes for easier, safer handling
- Includes round and trapezoidal steel hole blanks that fit in the unused recesses. Filling the unused recesses prevents debris buildup.
- Includes 3" steel mounting adapters with hook and loop mounting. Order additional adapters (#KIT2018-1 - Set of 6), or the replacement hook face sheet (#KIT2018 - Set of 6).

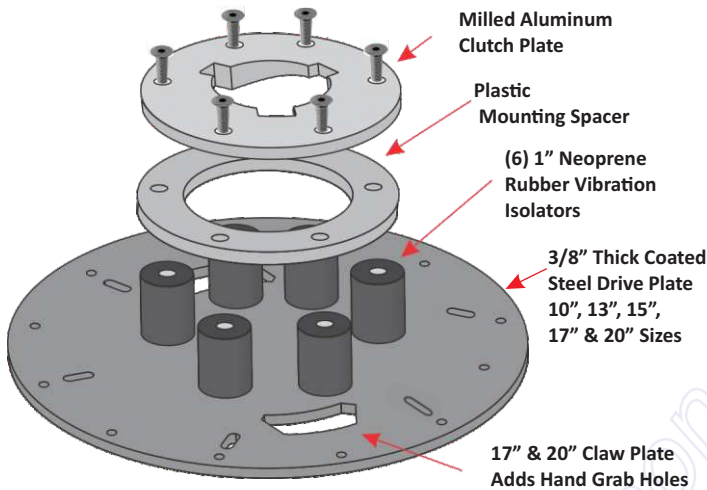
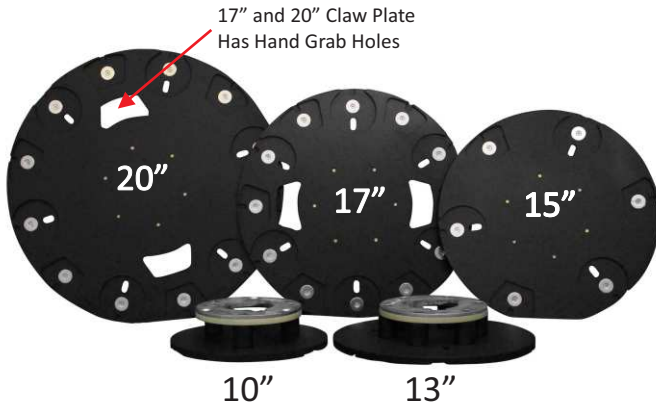

Includes Round Tool Adapters and Metal Hole Blanks to Fit the Milled Recesses

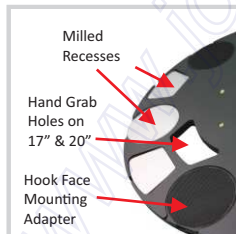

CLAW Steel Plates are Milled with Tool Mounting Recesses



3" Round Resin Tools Mount Fast and Reliably



CLAW Drives 3" Round and Trapezoidal Tools

Specifications

Model	CLAW 10	CLAW 13	CLAW 15	CLAW 17	CLAW 20
Part #	#Claw10	#Claw13	#Claw15	#Claw17	#Claw20
Claw Size	10"	12-5/8"	15"	16-5/8"	19-5/8"
Claw Speed	165 RPM	165 RPM	165 RPM	165 RPM	165 RPM
3" Round Tools (Included)	3	3	3	6	6
3" Round Blanks (Included)	3	3	3	6	6
Trapezoid Tools (Included)	0	3	3	6	6
Trapezoid Blanks (Included)	0	3	3	6	6
Tool Mounting	Mag-Lok Industrial Magnet System				
Weight	11 lbs.	18 lbs.	25 lbs.	27 lbs.	39 lbs.

Subject to Change Without Notice



Professional Polishing of Concrete & Stone

The Hawk Orbitec Planetary Driver makes quick work of polishing large concrete and stone areas. Six independent sealed ball bearing pedestals spin 3" tools up to 400 RPM. Orbitec extends tool life through cool running. The Orbitec with counter-rotating heads work 60% faster than fixed tool drivers.

Engineered Design

- The Orbitec Driver mounts under most conventional design 1.5 HP floor machines, driving the Orbitec plate at 175 RPM in a clockwise direction.
- The Orbitec mounting pedestals spin 3" diamond tools at 400 RPM in a counter-clockwise direction. This counter rotating operation spins diamond tools 60% faster than fixed mount drivers.
- The custom milled steel clutch plate provides easy on-and-off mounting on your floor machine.
- Two plate sizes; 13", and 20". Use the 20" plate for 17" and 20" floor machines.
- The electroplated 1/2" thick steel drive plate is built with replaceable pedestal heads
- These pedestals with are built with tool holding hook facing, securely mounting round diamond tools with loop backing. Diamond tools are quickly changed without shop tools.
- Add the optional dust ring and vacuum hose mounting kits to your Hawk floor machine for dust containment
- Add optional machine weights to your Hawk severe-duty floor machine for greater down pressure and faster floor prep results
- Order diamond tools separately



20" Orbitec
Shown with 3"
Replaceable
Diamond
Resin Tool
(Order Tools
Separately)



20" Orbitec
Top View Shows
Replaceable
Pedestal and Milled
Steel Clutch Plate



13" Orbitec
is Shown with
3 Tool Pedestals
(Order 3" Diamond
Tools Separately)



Specifications

Model	13" Orbitec Tool Driver	20" Orbitec Tool Driver
Part #	#HP0018-3	#HP0020-3
Machine Size	13 inch	17 & 20 inch
Driver Diameter	12.5 inch	19.5 inch
Machine Required	1.5 HP Severe Duty Floor Machine	
Machine RPM	165 rpm	165 rpm
Tool RPM	400 rpm	400 rpm
Weight	20 lbs.	30 lbs.



Driver Rotates at 175 RPM
Tools Counter-Rotate
at 600 RPM



Hook & Loop Mounting of
Tools on Pedestals

Subject to Change Without Notice

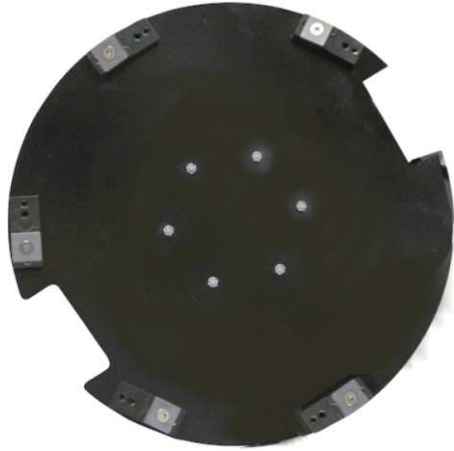

19" Steel Plate
for 17" &
20" Floor
Machine

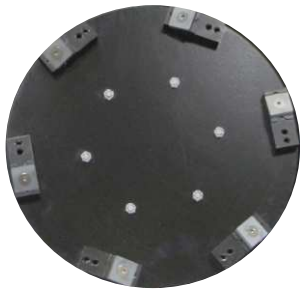

12" Steel Plate
for 13" Floor
Machine



Standard Blade
Mount for
Wide Cutting Edge



45° Mount for
Sharp Cutting Point



Specifications

Model	13" Scraper	20" Scraper	Replacement Cutter Set (3)
Part #	#HP0034	#HP0035	#HPA0033RC
Machine Size	13"	17", 20"	All
Drive Plate Size	12"	19"	-
Drive Plate Speed	165 RPM	165 RPM	-
Weight	27 lbs.	39 lbs.	1 lb.
Cutter Blade Size	1.0" x 1.0" x 1/4"		
Clutch Plate	Aluminum #NP9200 Plate with Custom Milled Design		
Riser	1.25" Tall Plastic		
Floor Machine Requirement	1.5 HP Severe Duty with 11:1 Industrial Gear Set		

Subject to Change Without Notice

Scraping, Soil & Coatings Removal

Use the Hawk Scraper to remove tile adhesives, carpet backing, industrial grease & soil, and coatings from hard surfaces. The Scraper drives six 1" x 1" carbide steel cutters on a dual-position rigid mount to scrape and scratch surfaces.

Drive the Scraper with a Hawk 1.5 HP, 175 RPM severe-duty floor machine. Higher speed machines are not recommended.

Engineered Design

- Two sizes - 13" and 20". The 20" Scraper fits 17" and 20" machines.
- 3/8" thick steel plate construction. The plate is electroplated for corrosion resistance.
- The plate is fit with six (6) tungsten steel cutter head holders, mounted with easily removed, allen head screws
- Each cutter head holder carries one (1) 1" x 1" carbide cutting blade. Each blade has 8 cutting edges.
- Mount the blade with a wide cutting edge, or turn 45 degrees to create a sharp cutting point. (See photo at left.)
- The Scraper plate mounts on the floor machine with a custom milled aluminum clutch plate with a riser (included). The riser is required for using the 20" Scraper on a 17" severe-duty buffer
- The aluminum clutch plate won't seize onto the drive hub
- Add the optional dust ring and vacuum mounting kits on your Hawk floor machine for handling dusty soils
- Add the optional machine weights to your Hawk floor machine for greater down pressure and faster scraping results

Safety Tips:

- 20" Scraper is built with mounting grip recess for safer handling and mounting
- Always unplug the floor machine before mounting or removing the Scraper driver

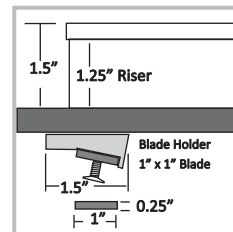

1" x 1" Blades Mount on the Holder with SS Bolts



17" and 20" Have Built-In Mounting Grip Recess



Carbide Steel Blades (3) per Replacement Kits



Scraper Mounts on the Severe-Duty Buffer with 9200 Style Clutch Plate



Rotary Floor Machine Accessories



Dust Pickup Systems
for 66 Frame Motors
#HP0031-DC17-STANDKIT
#HP0031-DC20-STANDKIT



Dust Pickup System for
180 Frame TE Motors
Rotary Machine Models
#HP0031-DC17-BRUTEKIT
#HP0031-DC20-BRUTEKIT



Dust Pickup Systems
for All Floating Head
Rotary Design Models
#HP0031-DC17-GLIDE
#HP0031-DC20-GLIDE



Vacuum Assembly Kit
#TH1011



Splash Guard
#SPLASH13 - 13"
#SPLASH15 - 15"
#SPLASH17 - 17"
#SPLASH20 - 20"



Splash Guard
SPLASH17-WD - 17"
SPLASH20-WD - 20"
For Glide, Merlin
Machines



Hexagonal Weight
for Rotary Motor Mount
#HPA0028-10P - 10 lbs.
#HPA0028-25P - 25 lbs.



4.5" Weight Post
Mount
for Hexagonal Weights#
#HP-0008-45STAND
(Use on 66 Frame
Motors)



Weight Post Mount
for Hexagonal Weights
#HP0008-45INCHBRUTE
Use on 180 Frame
TEFC Motors



20# Frame Weight*
#HPA0032-2P
Recommend for 11:1
XHD Gear Models Only

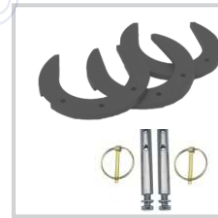

(1) 25# Horseshoe Wt.
#HPA0032-1P
Mounting Pin Kit
#HP0023
Best when used with
11:1 XHD Gear Models



Carriage Weight Set
fits Merlin TEXHD,
Merlin 360



Weight Set
(4) 20# fits Merlin
TEXHD, 2-Speed, 360
#A0340M-4



2.5 Gallon Solution Tank
for Mighty
A0001-BLK2.5
#A0001-BLK2.5TH
Telescoping Handle



4 Gallon Solution Tank
5 Stock Colors
4 Special Order Colors
#A0001-4-Color



4.5 Gallon
Solution Tank
for Glide, Merlin
#A0001-4Glide-Color



6 Gal. Solution Tank
for Merlin
#SME-2QQR6BLK



Frame Valve
for Solution Tank
for Brute, Merlin,
TEXHD, Pro, Osprey
#KIT2061



Power Lock Kit
Locks the Handle
in the "Up" position
for Brute, TEXHD
#HP0005-BLACK



Vacuum Assembly Kit
#FM1011



Private Brand Machines
7 Stock Colors
Plus Chrome



Rotary Brushes, Pads, Pad Drivers & Hardware



Tampico Polishing / Scrubbing Brush
#A0021 - 13"
#A0035 - 15"
#A0004 - 17"
#A0005 - 20"



Stiff Poly Scrub Brush
For general scrubbing
#A0020 - 13"
#A0036 - 15"
#A0002 - 17"
#A0003 - 20"



Lite Grit Brush
Scrub with flexible blue 150 grit bristles
#A0018-1 - 13"
#A0038-1 - 15"
#A0008-1 - 17"
#A0009-1 - 20"



Grit Brush
Strip/scrub with stiff black 80 Grit bristles
#A0018 - 13"
#A0038 - 15"
#A0008 - 17"
#A0009 - 20"



Nylon Carpet Brush
Scrub with soft & stiff nylon bristle mix.
#A0016 - 13"
#A0037 - 15"
#A0006 - 17"
#A0007 - 20"



Hawk Spin Safe Carpet Brush w/Adjustable S/S Glide Plate
Smooth adjustable plate protects the carpet.
#A0013-17 - 17"
#A0013-20 - 20"



Tufted Stiff Poly Bristle Pad Driver
3/4" long bristles. 3/4" riser.
#1007 - 12"
#A0018-1 W/R - 13"
#A0010-4 - 17"
#A0011-3 - 20"



Premium Double Hook Pad Driver
Molded polymer pad face has hundreds of individual hooks that securely grip and hold pads. Riser and showerfeed block
#A0017 - 13"
#A0034 - 15"
#A0010 - 17"
#A0011 - 20"



Hawk Lok™ Pad Driver
Molded design with universal clutch plate, built-in riser and a triangular showerfeed system handles the toughest jobs.
#0034-4 - 15"
#A0010-5 - 17"
#A0011-4 - 20"



Red Buffing Pad (5 Pack)
Use at 175-600 RPM for everyday cleaning and light scrubbing.
#A0026-13R-CS - 13"
#A0026-15R-CS - 15"
#A0026-17R-CS - 17"
#A0026-20R-CS - 20"



Black Stripping Pad (5 Pack)
Heavy-duty scrubbing and for removal of 2-4 coats of finish/sealer. Washable. Reusable.
#A0026-13BK-CS - 13"
#A0026-15BK-CS - 15"
#A0026-17BK-CS - 17"
#A0026-20BK-CS - 20"



Pad Centering Clamp - 2-Piece
2-piece clamp clips together securely holding any size pad.
#KIT2013 - Screw Lock
#KIT2014 - Spring Lock

*Rotary brush blocks are 2" smaller than machine size. Rotary pad driver blocks are 1" smaller than machine size. All have Universal clutch plate.

Floor Prep Tools



Surface Prep Scraper
(6) replaceable Tungsten Steel Scraping Heads, bolt to steel drive plate. Universal steel clutch plate.
#HP0034 - 13"
#Hp0034 - 20"



Orbitec Diamond Driver
(6) steel mounting cups hold 3" diamond tools. Universal steel clutch plate.
#HP0018 - 13"
#HP0020-3 - 20"



Diamond Pad Driver
#A0017DPD - 13"
N/A - 15"
#A0010DPD - 17"
#A0011DPD - 20"



Weighted Diamond Pad Driver
Steel pad driver block adds up to 64 lbs of pressure. Molded pins securely hold pads for HD floor prep.
#A0017WTDPD - 13" (25#)
#A0010WTDPD - 17" (46#)
#A0011WTDPD - 20" (64#)



Premium Sandpaper Driver
1" thick plywood block 1" riser and universal clutch plate. 1/2" thick cushion and steel mounting disc holds sandpaper
#A0014-HD - 17"
#A0014-1HD - 20"



Hawk Claw Diamond Tool Driver
with steel clutch plate
#CLAW10 - 10"
#CLAW13 - 13"
#CLAW15 - 15"
#CLAW17 - 17"
#CLAW20 - 20"



HAWK Orbital Floor Machine Accessories



Dust Control Kit
Skirt and hardware
#HP0031-DC-TIGER2014
#HP0031-DC-TIGER2814
#HP0031-DC-RAP
for G2 Raptor



Dust Control Kit
Factory Installed
Includes 6 qt. Tank
Vacuum, Dust Skirt,
Hardware
#TH1001



TigerHawk Sprayer
Conversion Kit
Factory Installed
with Motor Mounted
Pump, 4 Gallon
Solution Tank &
Hardware
#TH1010



Solution Tank
4 Gallon
#A0001-NAT4



2.5 Gallon Solution Tank
#A0001-BLK2.5
Black - fits Mighty 10
#A0001-BLK2.5TH
Black - fits telescoping
Mighty 10

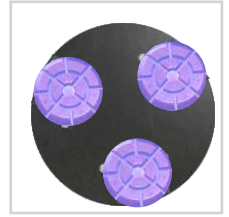

Hawk Claw 10
10" Claw Plate holds
(3) 3" Diamond Tools
#CLAW10 - 10"
Order Tools Separately



Red Orbital
Scrubbing Pads
5 Case



Black Orbital
Stripping Pads
5 Case



Green Astro
Textured
Surface Pads
2 Case



Hawk Surface
Prep Pads
Maroon
10 Case

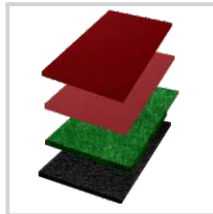

Orbital Pad Starter
Kit
(1) Green, (1) Red
(2) Black, (2) Maroon



Abrasive Screens
10 Case



Orbital Scrub Brush
#A0076-2014 - 20" x 14"
#A0076-2814 - 28" x 14"

Orbital Pad Color	10" x 14" for TigerHawk 1410	20" x 14" for TigerHawk 2014 G2 Raptor, Red Tail	28"x14" For TigerHawk 2814
Red (5/cs.)	A0066-1410-CS	A0066-2014-CS	A0066-2814-CS
Black (5/cs.)	A0069-1410-CS	A0069-2014-CS	A0069-2814-CS
Green Astro (4/cs.)	A0072-1410-CS	A0072-2014-CS	A0072-2814-CS
Maroon (10/cs.)	A0064-1410-CS	A0064-2014-CS	A0064-2814-CS
Orbital Starter Kit (1 black, 1 green, 1 red, 2 maroon)	A0075-1410PADKIT	A0075-2014PADKIT	A0075-2814PADKIT
Red Heat Screen 80 Grit	A0074-1410-80	A0074-2014-80	A0074-2814-80
Red Heat Screen 120 Grit	A0074-1410-120	A0074-2014-120	A0074-2814-120
Red Heat Screen 180 Grit	A0074-1410-180	A0074-2014-180	A0074-2814-180

HAWK ENTERPRISES

**Rotary Floor Machines • Orbital Floor Machines • High Speed Burnishers
Air Movers • Vacuums • Specialty Cleaning Equipment • Parts & Supplies**

